

CHALLENGE®

Shaft Mounted Speed Reducer Catalogue



www.challengept.com



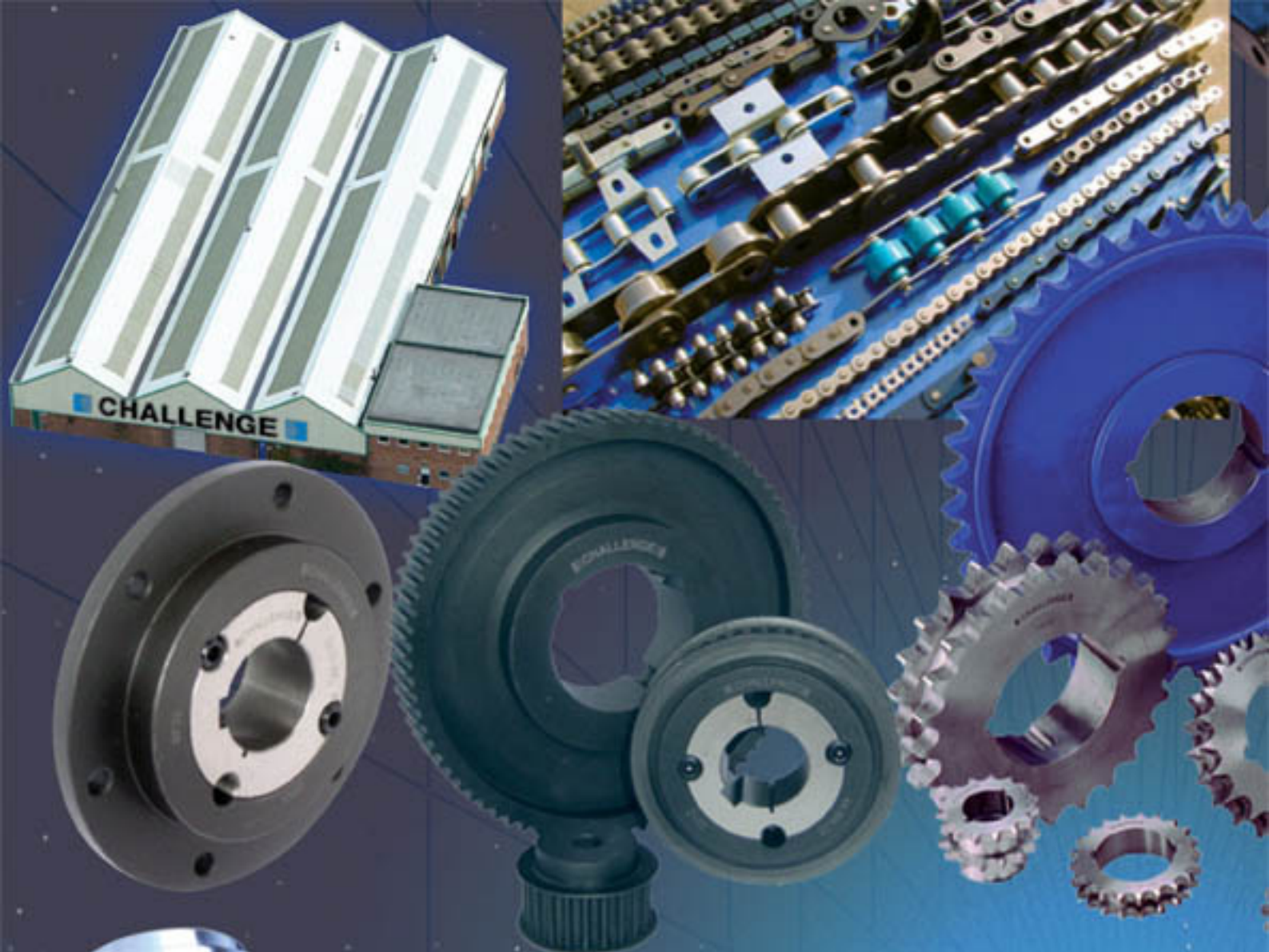

Never a problem, always a...

 **CHALLENGE** ®





CHALLENGE
Roller Chain
10BSS-2 x 5

ISO
9001

CHALLENGE

10BSS-2 x 5m

CHALLENGE

Never a problem always a ...





CHALLENGE PRODUCTS

PRECISION ROLLER CHAIN, IN STEEL, STAINLESS STEEL & ZINC/NICKEL PLATED

LEAF CHAIN

HEAVY DUTY DRIVE CHAIN

WELDED STEEL CHAIN (DRAG AND MILL CHAIN)

FOOD INDUSTRY CHAIN

AGRICULTURAL CHAIN

SPECIAL CHAIN AND ATTACHMENT CHAIN

CONVEYOR CHAIN

BLOCK CHAIN

ENGINEERED BUSH CHAIN

PALM OIL CHAIN

DROP FORGED CHAIN

SUGAR CHAIN

TAPER BORE & PILOT BORE V-PULLEYS

SYNCHRONOUS PULLEYS

POLY V PULLEYS

TAPER BUSHES

MI-LOCK PULLEYS AND BUSHES

WEDGE AND CLASSICAL V-BELTS

TAPER BORED SPROCKETS

PILOT BORED & PLATEWHEEL SPROCKETS

FINISH BORED SPROCKETS

WELD-ON-HUBS AND BOLT-ON-HUBS

HRC COUPLINGS

FFX TYRE COUPLINGS

JAW COUPLINGS

NPX COUPLINGS

RPX COUPLINGS

CHAIN COUPLINGS

SHAFT MOUNTED SPEED REDUCERS (SMSR + TXT)

TORQUE LIMITERS

CLAMPING ELEMENTS

GEAR MOTORS

ELECTRIC MOTORS

MOTOR MOUNTS

SELF LUBE BEARING UNITS

PLUMMER BLOCKS

BEARINGS

Challenge Group Companies

AUSTRALIA

Challenge Power Transmission (Aust) Pty Ltd
B11, Scoresby Industry Park
Janine Street
Scoresby
Victoria 3179
Australia
Tel: (03) 9763 6701 Fax: (03) 9764 0890
Email: aussales@challengept.com

CZECH REPUBLIC

Challenge PT (Czech) s.r.o.
Hulínská 1799, areál Magneton
767 01 Kroměříž
Česká Republika
Tel: +420 573 334 106 Fax: +420 573 330 556
Email: czsales@challengept.com

GERMANY

Challenge Power Transmission GmbH
In der Neuwies 1
D-35745 Herborn
Germany
Tel: +49 2772 575860 Fax: +49 2772 5758620
Email: desales@challengept.com

IRELAND

Challenge Power Transmission (Ireland) Ltd
Unit 202
Holly Road
Western Industrial Estate
Dublin 12
Eire
Tel: +353 1 4566311 Fax: +353 1 4566312
Email: ireland@challengept.com

CHINA (Shijiazhuang)

Challenge Power Transmission (SHZ) Plc
South of Daxizhang
High Technology Developing Area
Shijiazhuang 050035
China
Tel: +86 311-85385510 Fax: +86 311 8538 5590
Email: cnsales@challengept.com

SOUTH AFRICA

Challenge Power Transmission Africa (Pty) Ltd
Cnr Estee Ackermann and Yaldwyn Streets
Jet Park, Boksburg
Gauteng, Johannesburg
1459
South Africa
Tel: +27 11 3976115 Fax: + 27 11 3978494
Email: sasales@challengept.com

UNITED KINGDOM

Challenge Power Transmission Ltd
Merryhills Enterprise Park
Park Lane
Wolverhampton
WV10 9TJ
United Kingdom
Tel: +44 1902 866116 Fax: +44 1902 866117
Email: uk@challengept.com

CHINA (Ningbo)

Challenge Power Transmission (Ningbo) Ltd
Bao Zhan Avenue, Xiao Bai Village,
Dong Wu Town, Yin Zhou District, Ningbo City,
Zhejiang Province, China
Tel: +86 574 8833 4378 Fax: +86 574 8833 4379
Email: ningbo.sales@challengeproduction.com

Technical Information

Engineering Units

SI units

The table below shows units corresponding to the International system of units, more commonly called SI (Système International d'Unités) From these , all other units can be derived.

quantity	unit	metric symbol	imperial symbol
mass	kilogram	kg	pound (lb)
length	metre	m	inch (in)
time	second	s	s
temperature	Kelvin	K	Fahrenheit (F)
electric current	Ampere	A	A

Some common units in general use appertaining to Power Transmission

quantity	unit	metric symbol	imperial symbol
force	Newton	N	pound force (lbf)
	kilogram force	kgf	
torque	Newton metre	Nm	pound inch (lbf.in)
	kilogram metre	kgf.m	pound foot (lbf.ft)
power	Watt or kilowatt	W kW	horsepower hp
	pressure	Pascal	Pa
bar		bar	psi
temperature	degree Celsius	°C	°F
frequency	Hertz	Hz	cycles/second (c/s)
speed – linear	metres/second	m/s	feet/min
speed – angular	revolutions per minute (rpm)	rev/min	rev/min
inertia	MR ²	kg.m ²	lb.in ²
			lb.ft ²
electrical potential	Volt	V	
electrical resistance	Ohm	Ω	
electrical capacity	Farad	F	

Common multiples and sub-multiples

prefix	symbol	factor
micro	μ	÷ 1,000,000
milli	m	÷ 1,000
kilo	k	× 1,000
mega	M	× 1,000,000
tera	T	× 1,000,000,000,000

Common conversion factors

The factors given below are typical of those used in Power Transmission engineering :-

Metric to Imperial are on the left and the converse on the right

Length

millimetres (mm) x 0.0394 = inches (ins) inches x 25.4 = mm
 metres (m) x 39.37 = inches inches x 0.0254 = metres (m)
 metres x 3.281 = feet (ft) feet x 0.305 = metres
 kilometres x 0.6213 = miles miles x 1.61 = kilometres

Force

Newtons x 0.225 = pound force (lbf) lbf x 4.45 = Newtons (N)
 kilogram force (kgf) x 2.205 = lbf lbf x 0.454 = kgf
 kgf x 9.81 = Newtons
 N x 0.102 = kgf

Torque

Newton metre (Nm) x 0.735 = pounds feet (lbf.ft)
 Newton metre (Nm) x 8.85 = pounds inches (lbf.ins)
 kilogram force metre (kgf.m) x 9.81 = Newton metre

Power

kilowatt (kW) x 1.34 = horse power (hp) hp x 0.746 = kW

Note – the French Cheval-Vapeur (CV) and the German Pferdestärke (PS) are virtually the same value of horse power.
 To be exact, hp x 0.98 = CV or PS

Inertia

kg.m² x 23.73 = lb.ft²

Temperature

°C = $\frac{5}{9} \times (°F - 32)$ °F = $\frac{9}{5} \times °C + 32$

Pi (π)

The ratio between the circumference and diameter of a circle is π
 diameter x π = circumference

π = **3.1416**

so diameter x 3.1416 = circumference

Common formulae useful in Power Transmission

Torque, Power and Speed

$$\text{Power (kW)} = \frac{\text{Torque (Nm)} \times \text{rev/min}}{9550}$$

$$\text{Torque (Nm)} = \frac{\text{Power (kW)} \times 9550}{\text{rev/min}}$$

'V' - Drive shaft/bearing loads

The following simple formulae give a good indication as to the static and dynamic loads imposed on shafts/bearings by 'V'- Belts

It is useful formulae being based on the actual setting force used to tension the drive

$$\begin{aligned} T_s &= \text{static tension} \\ T_c &= \text{centrifugal tension} \\ T_d &= \text{dynamic tension} \\ T_s &= 16 \times 2 \times P \times B = N \\ T_c &= M \times S^2 \times 2 \times B = N \\ T_d &= T_s - T_c = N \end{aligned}$$

where :-

$$\begin{aligned} 16 &= \text{a constant} \\ 2 &= \text{the tight and slack sides of the belt} \\ P &= 80\% \text{ of the higher tensioning force figure (1.3 x column) - kgf} \\ &\quad \text{(from page 148 in the CHALLENGE technical catalogue)} \\ B &= \text{the number of belts on the drive} \\ M &= \text{belt mass per unit length - kilogram per metre - kg/m} \\ &\quad \text{(from page 132 in the CHALLENGE technical catalogue)} \\ S &= \text{belt speed in metres per second (m/s)} \\ S &= \frac{d \times n}{19100} \text{ m/s} \end{aligned}$$

whereby :-

$$\begin{aligned} d &= \text{small pulley pitch diameter - mm} \\ n &= \text{rotational speed of small pulley - rev/min} \end{aligned}$$

Example

Calculate the dynamic tension from the following drive.

90kW 1440 rev/min direct start electric motor to a Belt Conveyor running at 400 rev/min for 12 hours/day carrying copper ore and absorbing 81 kW.

Motor shaft is 75 mm, conveyor shaft 105 mm. 1200 mm drive centres

The drive chosen is :-

Motor Pulley: 280 x 5 SPB with a 3535 / 75 mm bore taper bush

Conveyor pulley: 1000 x 5 SPB with a 4545 / 105 mm bore taper bush

Belts: 5 off SPB 4500 Wedge Belts giving 1191 mm drive centres

Calculating the Dynamic Tension

$$\begin{aligned} T_s &= 16 \times 2 \times P \times B \\ &= 16 \times 2 \times (8.2 \times 9.81 \times 0.80) \times 5 = 10297 \text{ N} \end{aligned}$$

$$T_c = M \times S^2 \times 2 \times B$$

whereby :-

$$\begin{aligned} M &= 0.19 \text{ kg/m} \\ S &= \frac{d \times n}{19100} = \frac{280 \times 1440}{19100} = 21.11 \text{ m/s} \end{aligned}$$

$$T_c = 0.19 \times 21.11^2 \times 2 \times 5 = 847 \text{ N}$$

$$T_d = T_s - T_c$$

$$T_d = 10297 - 847$$

$$= 9450 \text{ N}$$

The calculation of weights

Weight is mass measured vertically and simple empirical formulae can be used to calculate the weight of round and rectangular objects:

Round objects

diameter (mm) squared x length (m) x factor = weight (kgf)

$$\text{factor for mild steel} = 0.00617$$

$$\text{factor for stainless steel} = 0.00636$$

$$\text{factor for cast iron} = 0.00598$$

Example

calculate the weight of a 25mm diameter rod of mild steel with a length 500 mm.

$$25^2 \times 0.5 \times 0.00617 = 1.928 \text{ kgf}$$

Rectangular objects

depth (mm) x height (mm) x length (m) x factor = weight (kgf)

$$\text{factor for mild steel} = 0.00785$$

$$\text{factor for stainless steel} = 0.00809$$

$$\text{factor for cast iron} = 0.00761$$

Example

calculate the weight of a rectangular mild steel bar 25 mm x 35 mm with length 600 mm

$$25 \times 35 \times 0.6 \times 0.00785 = 4.121 \text{ kgf}$$

CHALLENGE®

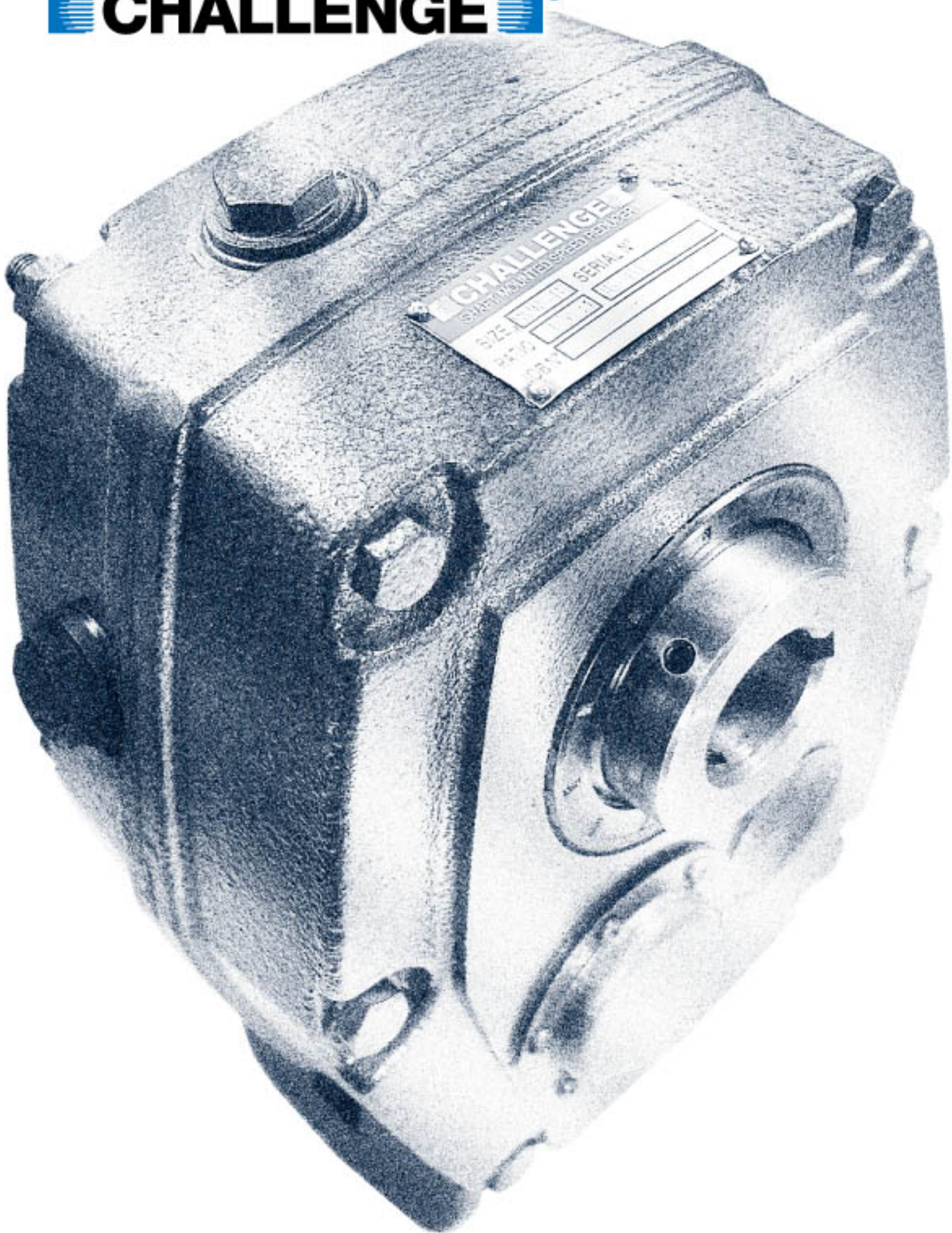

Shaft Mounted Speed Reducers

Metric Range

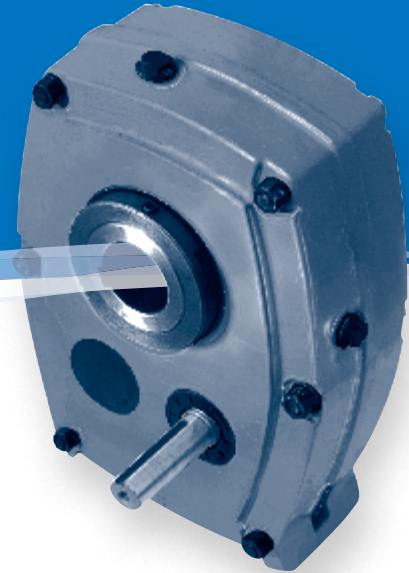

Features

The Challenge SMSR stands tall amongst the crowd. Packed full of attention to detail, the Challenge SMSR delivers performance in the harshest of applications.

Shaft mounted drives remove the need for couplings, mounting plinths and have infinitely variable ratios due to the belt drive. They are also incredibly simple to fit and can be mounted in any position as no motor base is required.

- Grip-Loc hubs now available for simple installation and removal
- Includes complete torque arm assembly
- Interchangeable with most other manufacturers
- Production line manufacturing guarantees tolerances and consistent quality.
- Gears produced on German manufactured hobbing centres to achieve the highest quality helical gear components.
 - Pinions; 8620 steel
 - Gears; 20MnCr5 steel
- All gears are ground
- Final heat treatment includes gas carburising to a depth of 1mm, then grinding to DIN class 6.
- Castings crack tested
- All units test run prior to final quality control checks
- Full traceability guaranteed with unique Challenge serial number.
- Backstops also available to prevent reversing
- Drive ratios exceed 150:1 with a belt drive
- Double lipped oil seals used throughout
- Standard ball and cylindrical roller bearings used - in stock around the world

Shaft Mounted Speed Reducer

Shaft Mounted Speed Reducer selection procedure

1] Service Factor.

From Table 1 on page 357, select the service factor that is appropriate for the application

2] Design Power.

Multiply the absorbed power of the driven machine by the service factor, from step 1) to obtain the design power.

If the absorbed power is not known, use the motor power

3] SMSR gear unit size selection.

Refer to the power rating Tables on pages 357 and 358 then read down the left hand vertical column to the required output speed. (interpolate if the exact speed is not listed).

Read horizontally across on the speed line until a power equal to or in excess of the design power, from step 2), is reached.

Read vertically to the top of the column to obtain the correct size of SMSR unit.

The ratio of the chosen unit is determined by the required output speed.

Go to page 371 or 372 in order to check the chosen SMSR will fit the driven machine shaft.

Wedge belt drive selection procedure.

Two methods are used for the belt drive selection.

One for 1440 rev/min electric motors and secondly for all other speeds.

1440 rev/min electric motor speed.

a] Output speed.

Refer to the Wedge belt drive selection pages (pages 359 to 367) for the chosen gear unit size. Read down the left hand column headed 'output speed' until a speed equal to or near to that required is found.

b] Pulley pitch diameters.

Read across from the chosen output speed to obtain the pulley diameters for the motor shaft and SMSR input shaft

On smaller size gear units, it may well be that single belt drives are recommended. If, on such drives, two belts are preferred, special attention must be made to belt tensioning.

If in any doubt, please contact CHALLENGE.

c] Centre distance.

Refer to page 160 in order to calculate the correct belt length for the required centre distance

Other prime mover speeds

a] SMSR unit input shaft speed.

Multiply the chosen SMSR gear unit output speed by its exact speed ratio to obtain the SMSR gear unit input shaft speed.

The exact gear ratio of the chosen SMSR can be found at the bottom of the SMSR dimension Table on page 369 column 2 .

b] Selection of Wedge belt drive.

The correct Wedge belt can be designed by referring to the selection procedure on page 160.

Shaft Mounted Speed Reducer selection example

Select a CHALLENGE Shaft Mounted Speed Reducer to drive a rotary kiln which absorbs 0.95 kW when running at 20 rev/min for upto 8 hours/day.

The prime mover is a 1.1 kW, 1440 rev/min electric motor with a star-delta starter and a 24 mm shaft.

The kiln has a 50 mm shaft and 450 mm drive centres are required.

1] Service Factor.

From Table 1 on page 357, the chosen service factor is 1.25.

2] Design Power.

Using the kiln absorbed power of 0.95 kW, the design power is :-
 $0.95 \times 1.25 = 1.19 \text{ kW}$

3] SMSR gear unit size selection.

From the SMSR power rating Table on page 358, a size D13 or D20 will transmit 1.58 kW at 20 rev/min which is excess of the required 1.19 kW from step 2).

A size D20 rather than a D13 is chosen as it will utilize a more economically priced Wedge belt drive.

On checking the hub sizes on page 371, it is seen that the D20 has a 50 mm standard hub bore which matches the kiln shaft of 50 mm.

Wedge belt drive selection procedure.

As the motor speed is 1440 rev/min, the following selection method is used :-

1440 rev/min electric motor speed.

a] Output speed.

Refer to the drive selection page 361 for SMSR size 'D' units. Read down the left hand column to required output speed of 20 rev/min.

b] Pulley pitch diameters.

Read across from the chosen output speed to obtain the prime mover and SMSR input shaft pulley diameters. The electric motor to be fitted with a 71 x 1 SPZ pulley and the SMSR input shaft with a 250 x 1 SPZ

c] Centre distance.

Refer to page 160 and by using the appropriate formulae, an SPZ1420 will give a centre distance of 449 mm.

Drive Specification.

SMSR size: D20 with a standard hub bore of 50 mm

Motor pulley: 71 x 1 SPZ with taper bush size 1108 bored 24 mm

SMSR input shaft pulley: 250 x 1 SPZ with taper bush 2012 bored 25 mm

An SPZ1420 Wedge belt gives a centre distance of 449 mm.

Shaft Mounted Speed Reducer

Table 1, Service Factors

Type of driven machine	Number of hours per day running		
	under 10	10 - 16	over 16
Uniformly loaded applications Agitators and mixers - uniform density, centrifugal blowers, belt conveyors and elevators, non-reversing laundry machines, line shafts, centrifugal and rotary pumps, wire drawing machines	1.00	1.12	1.25
Moderate shock load applications Agitators and mixers – variable density, conveyors – medium duty, cranes, feeders – pulsating loads, hoists, kiln, other laundry machinery, lifts, piston pumps with 3 or more cylinders, paper making machinery, rubber mixers and calenders, rotary screens, textile machinery	1.25	1.40	1.60
Heavy duty machinery Brick making machinery, heavy duty conveyors, crushers, reciprocating feeders, hammer mills, piston pumps with 1 or 2 cylinders, rubber masticators, vibrating machines	1.60	1.80	2.00

SMSR Power Rating Table kW (Ratio 5:1) Single Reduction

Output rev/min	SMSR Size							
	B5	C5	D5	E5	F5	G5	H5	J5
100	2.02	3.14	5.20	8.03	11.44	19.03	27.50	58.52
110	2.15	3.32	5.50	8.44	12.06	20.06	29.00	61.89
120	2.27	3.51	5.80	8.85	12.67	21.10	30.49	65.25
130	2.40	3.70	6.09	9.26	13.29	22.13	31.99	68.62
140	2.53	3.88	6.39	9.68	13.90	23.17	33.48	71.98
150	2.65	4.07	6.69	10.09	14.52	24.20	34.98	75.35
160	2.78	4.23	6.95	10.45	15.03	25.21	36.37	78.32
170	2.91	4.38	7.21	10.80	15.53	26.22	37.75	81.29
180	3.03	4.54	7.47	11.16	16.04	27.24	39.14	84.26
190	3.16	4.69	7.73	11.52	16.54	28.25	40.52	87.23
200	3.29	4.85	7.99	11.88	17.05	29.26	41.91	90.20
210	3.42	4.99	8.20	12.19	17.47	27.24	43.14	92.84
220	3.55	5.12	8.42	12.50	17.89	25.21	44.37	95.48
230	3.68	5.25	8.63	12.80	18.30	23.19	45.61	98.12
240	3.81	5.39	8.85	13.11	18.72	21.16	46.84	100.76
250	3.94	5.52	9.06	13.42	19.14	19.14	48.07	103.40
260	4.07	5.64	9.25	13.71	19.47	22.95	49.13	105.82
270	4.20	5.76	9.43	13.99	19.80	26.75	50.18	108.24
280	4.33	5.87	9.61	14.28	20.13	30.56	51.24	110.66
290	4.46	5.99	9.79	14.56	20.46	34.36	52.29	113.08
300	4.59	6.11	9.98	14.85	20.79	38.17	53.35	115.50
310	4.71	6.21	10.15	15.11	21.05	38.92	54.19	117.92
320	4.84	6.32	10.33	15.38	21.32	39.67	55.02	120.34
330	4.96	6.43	10.51	15.64	21.58	40.41	55.86	122.76
340	5.09	6.54	10.68	15.91	21.85	41.16	56.69	125.18
350	5.21	6.64	10.86	16.17	22.11	41.91	57.53	126.00
360	5.34	6.75	11.04	16.43	22.33	42.50	58.12	128.10
370	5.46	6.85	11.22	16.70	22.55	43.10	58.72	129.20
380	5.58	6.95	11.40	16.96	22.77	43.69	59.31	130.20
390	5.71	7.05	11.59	17.23	22.99	44.29	59.91	131.30
400	5.83	7.15	11.77	17.49	23.21	44.88	60.50	134.00
Torque (Nm) @ 100 rev/min	193	299	497	767	1093	1817	2626	5589

Note: Challenge do not recommend the use of backstops on 5:1 units as this affects the units power ratings. Should this be necessary please contact the Challenge Technical Department.

Shaft Mounted Speed Reducer

SMSR Power Rating Table kW (Ratio 13:1 & 20:1)

Double Reduction

Output rev/min	SMSR Size										
	B13/B20	C13/C20	D13/D20	E13/E20	F13/F20	G13/G20	H13/H20	J13/J20	S 20	K 20	L 20
10	0.29	0.49	0.82	1.25	1.97	3.11	4.90	7.80	11.0	14.6	23.0
12	0.36	0.58	0.96	1.48	2.45	3.71	5.90	9.20	13.1	17.3	27.3
14	0.42	0.67	1.11	1.73	2.71	4.30	6.80	10.70	15.2	20.0	31.6
16	0.47	0.77	1.27	1.97	3.09	4.89	7.70	12.10	17.3	22.6	35.9
18	0.53	0.86	1.41	2.20	3.44	5.48	8.70	13.60	19.3	25.1	40.1
20	0.59	0.96	1.58	2.43	3.82	6.08	9.50	15.10	21.4	27.6	44.3
22	0.63	1.04	1.73	2.67	4.18	6.63	10.40	16.40	23.4	30.1	48.4
24	0.69	1.13	1.86	2.89	4.55	7.22	11.30	17.90	25.4	32.6	52.5
26	0.75	1.22	2.02	3.13	4.91	7.79	12.10	19.30	27.3	35.1	56.6
28	0.81	1.32	2.18	3.36	5.27	8.35	13.10	20.60	29.3	37.5	60.6
30	0.86	1.41	2.32	3.58	5.63	8.92	13.90	22.50	31.2	39.8	64.7
32	0.92	1.50	2.47	3.81	5.98	9.49	14.80	23.60	33.2	42.2	68.6
34	0.98	1.60	2.63	4.04	6.34	10.04	15.70	25.10	35.1	44.5	72.6
38	1.10	1.79	2.91	4.48	7.05	11.12	17.40	27.60	39.0	49.0	80.4
40	1.16	1.87	3.07	4.71	7.41	11.87	18.20	29.00	40.8	51.2	84.2
42	1.20	1.96	3.19	4.92	7.75	12.39	19.30	30.10	42.6	53.2	87.9
46	1.30	2.13	3.48	5.37	8.28	13.65	21.10	32.60	46.4	57.1	95.1
50	1.42	2.30	3.78	5.81	9.07	14.60	22.80	35.00	50.1	60.8	102.2
52	1.47	2.37	4.00	6.03	9.14	15.23	23.40	35.60	51.6	62.7	105.0
54	1.52	2.47	4.14	6.23	9.42	15.86	24.40	36.30	52.8	64.5	109.2
58	1.64	2.61	4.43	6.66	10.02	16.80	25.80	38.00	55.7	68.0	115.5
62	1.76	2.77	4.71	7.23	10.61	17.96	27.50	40.20	57.8	71.5	121.8
66	1.86	2.94	5.01	7.68	11.24	19.01	29.70	42.50	60.4	75.0	128.1
70	1.96	3.07	5.13	8.11	11.76	20.16	30.60	44.70			
74	2.06	3.18	5.42	8.54	12.39	21.11	32.00	47.00			
78	2.15	3.32	5.70	8.97	12.92	22.26	33.60	49.20			
80	2.23	3.39	5.81	9.19	13.23	22.47	34.30	50.20			
85	2.34	3.58	6.14	9.71	13.97	23.31	36.20	52.80			
90	2.48	3.79	6.49	10.24	14.60	24.57	37.90	55.30			
95	2.61	4.00	6.81	10.50	15.44	25.83	39.00	58.00			
100	2.73	4.19	7.15	11.03	16.17	27.09	40.70	60.50			
105	2.85	4.41	7.48	11.55	17.01						
110	2.98	4.62	7.81								
115	3.11										
Torque (Nm) @ 10 rev/min	277	468	783	1194	1881	2970	4680	7449	10505	13943	21965

Note: The wavy line ~~~~~ indicates maximum output speed for 20:1 ratio units, for speeds above this limit use 13:1 or 5:1 ratio units.

Shaft Mounted Speed Reducer

Wedge Belt Drives for 1440 rev/min Electric Motors

B 5:1

Nominal Output Speed	Pulley Ratio	Pulley Motor Dia (mm)	Gearbox	Number of Belts
51	5.63	71	400	1SPZ*
57	5.00	80	400	1SPZ*
64	4.44	90	400	1SPZ*
71	4.00	100	400	1SPZ*
80	3.57	112	400	1SPZ*
86	3.32	95	315	1SPZ*
91	3.15	100	315	1SPZ*
97	2.94	85	250	2SPZ
101	2.82	71	200	2SPZ
107	2.67	75	200	2SPZ
113	2.54	71	180	2SPZ
119	2.40	75	180	2SPZ
128	2.23	112	250	1SPZ*
134	2.13	75	160	2SPZ
137	2.09	67	140	3SPZ
145	1.97	71	140	3SPZ
151	1.89	106	200	1SPA*
160	1.79	112	200	1SPA*
168	1.70	106	180	1SPA*
171	1.67	67	112	3SPZ
177	1.61	112	180	2SPZ
181	1.58	71	112	3SPZ
187	1.53	118	180	1SPA*
190	1.50	100	150	2SPA
200	1.43	112	160	1SPA*
205	1.39	90	125	2SPZ
210	1.36	118	160	1SPA*
216	1.32	106	140	2SPA
222	1.29	140	180	1SPZ*
228	1.25	112	140	1SPA*
235	1.21	132	160	1SPA*
242	1.18	95	112	2SPZ
250	1.14	140	160	1SPA*
256	1.12	112	125	1SPA*
266	1.07	140	150	1SPA*
270	1.06	90	95	3SPZ
285	1.00	100	100	2SPZ
302	1.06	90	85	3SPZ
306	1.07	150	140	1SPA*
319	1.12	140	125	1SPA*
324	1.14	150	132	1SPA*
336	1.18	100	85	3SPZ
342	1.20	180	150	1SPA*
355	1.24	112	90	3SPZ
362	1.27	150	118	1SPZ*
365	1.28	160	125	2SPZ
376	1.32	112	85	3SPZ
380	1.33	200	150	1SPA*
387	1.36	160	118	2SPA
396	1.39	125	90	3SPZ

B 13:1

Nominal Output Speed	Pulley Ratio	Pulley Motor Dia (mm)	Gearbox	Number of Belts
17	5.97	67	400	1SPZ*
22	4.70	67	315	1SPZ*
24	4.20	75	315	1SPZ*
28	3.73	67	250	1SPZ*
31	3.33	75	250	1SPZ*
34	2.99	67	200	1SPZ*
36	2.82	71	200	1SPZ*
38	2.69	67	180	1SPZ*
41	2.54	71	180	1SPZ*
43	2.39	67	160	1SPZ*
46	2.25	71	160	1SPZ*
48	2.13	75	160	1SPZ*
51	2.00	80	160	1SPZ*
55	1.88	85	160	1SPZ*
59	1.75	80	140	1SPZ*
62	1.65	85	140	1SPZ*
64	1.60	100	160	1SPZ*
66	1.56	90	140	1SPZ*
70	1.47	85	125	1SPZ*
74	1.39	90	125	1SPZ*
78	1.32	95	125	1SPZ*
82	1.25	100	125	1SPZ*
86	1.20	71	85	2SPZ
91	1.13	71	80	2SPZ
97	1.06	100	106	1SPA*
103	1.00	106	106	1SPA*
109	1.06	112	106	1SPA*
115	1.12	125	112	1SPZ*
117	1.13	85	75	2SPZ
121	1.18	125	106	1SPA*
123	1.20	90	75	2SPZ
125	1.21	160	132	1SPA*
129	1.25	140	112	1SPZ*
130	1.27	95	75	2SPZ
132	1.29	180	140	1SPA*
136	1.32	140	106	1SPA*
140	1.36	180	132	1SPA*
143	1.39	125	90	2SPZ
146	1.42	150	106	1SPA*
148	1.44	180	125	1SPA*
151	1.47	125	85	2SPZ
154	1.49	112	75	2SPZ
155	1.51	160	106	1SPA*
157	1.53	180	118	1SPA*
161	1.56	125	80	2SPZ
165	1.61	180	112	1SPA*
170	1.65	140	85	2SPZ
172	1.67	125	75	2SPZ
175	1.70	180	106	1SPA*
180	1.75	140	80	2SPZ

B 20:1

Nominal Output Speed	Pulley Ratio	Pulley Motor Dia (mm)	Gearbox	Number of Belts
10	6.67	75	500	2SPZ
11	6.25	80	500	2SPZ
12	5.97	67	400	1SPZ*
13	5.26	95	500	2SPZ
14	5.00	80	400	1SPZ*
15	4.70	67	315	1SPZ*
16	4.20	75	315	1SPZ*
17	3.94	80	315	1SPZ*
18	3.73	67	250	1SPZ*
19	3.57	112	400	1SPZ*
20	3.52	71	250	1SPZ*
21	3.33	75	250	1SPZ*
22	3.12	80	250	1SPZ*
23	2.99	67	200	1SPZ*
24	2.82	71	200	1SPZ*
25	2.78	90	250	1SPZ*
26	2.69	67	180	1SPZ*
27	2.54	71	180	1SPZ*
29	2.39	67	160	1SPZ*
30	2.25	71	160	1SPZ*
32	2.13	75	160	1SPZ*
33	2.09	67	140	1SPZ*
34	2.00	80	160	1SPZ*
35	1.97	71	140	1SPZ*
37	1.87	67	125	1SPZ*
39	1.76	71	125	1SPZ*
40	1.70	106	180	1SPA
41	1.67	67	112	1SPZ*
43	1.58	71	112	1SPZ*
44	1.56	90	140	1SPZ*
45	1.53	118	180	1SPA
46	1.49	67	100	1SPZ*
47	1.47	85	125	1SPZ*
48	1.42	67	95	1SPZ*
49	1.39	90	125	1SPZ*
50	1.36	132	180	1SPA
51	1.34	71	95	1SPZ*
52	1.32	85	112	1SPZ*
54	1.27	71	90	1SPZ*
55	1.24	90	112	1SPZ*
57	1.20	75	90	1SPZ*
58	1.18	85	100	1SPZ*
61	1.13	75	85	1SPZ*
62	1.11	90	100	1SPZ*
64	1.07	140	150	1SPA
65	1.06	80	85	1SPZ*
69	1.00	80	80	1SPZ*
72	1.05	100	95	1SPZ*
73	1.07	80	75	2SPZ
76	1.11	100	90	1SPZ*

* Single belt drives can be used, however, two belts can also be used without overloading the SMSR input shaft bearings.

Shaft Mounted Speed Reducer

Wedge Belt Drives for 1440 rev/min Electric Motors

C 5:1

Nominal Output Speed	Pulley Ratio	Pulley Motor Dia (mm)	Gearbox	Number of Belts
51	5.63	71	400	2SPZ
61	4.70	67	315	2SPZ
64	4.44	71	315	2SPZ
71	4.00	100	400	1SPA*
76	3.77	106	400	1SPA*
80	3.57	112	400	1SPZ*
86	3.33	75	250	3SPZ
89	3.20	125	400	1SPZ*
94	3.03	132	400	1SPA*
100	2.86	140	400	1SPZ*
107	2.67	118	315	1SPA*
113	2.52	125	315	1SPA*
120	2.39	132	315	1SPA*
127	2.25	80	180	3SPZ
134	2.13	75	160	3SPZ
143	2.00	100	200	2SPZ
151	1.89	132	250	1SPA*
160	1.79	140	250	1SPA*
168	1.70	106	180	2SPA
171	1.67	150	250	1SPA*
177	1.61	112	180	2SPZ
178	1.60	125	200	1SPA
187	1.53	118	180	2SPA
190	1.50	100	150	2SPA
200	1.43	140	200	1SPA*
205	1.39	90	125	3SPZ
209	1.36	132	180	2SPA
214	1.33	150	200	1SPA*
222	1.29	140	180	2SPZ
223	1.28	125	160	1SPA
235	1.21	132	160	2SPA
242	1.18	106	125	2SPA
250	1.14	140	160	2SPZ
254	1.12	80	90	4SPZ
257	1.11	180	200	1SPA*
269	1.06	118	125	2SPA
285	1.00	100	100	3SPZ
300	1.05	118	112	2SPA
306	1.07	150	140	2SPA
317	1.11	200	180	1SPA*
326	1.14	160	140	2SPZ
336	1.18	100	85	4SPZ
338	1.19	140	118	2SPA
342	1.20	150	125	2SPA
355	1.24	112	90	4SPZ
363	1.27	150	118	2SPA
367	1.29	180	140	2SPZ
375	1.32	125	95	3SPZ
387	1.36	160	118	2SPA
396	1.39	250	180	1SPA*

C 13:1

Nominal Output Speed	Pulley Ratio	Pulley Motor Dia (mm)	Gearbox	Number of Belts
18	5.97	67	400	1SPZ*
21	5.00	80	400	1SPZ*
25	4.20	75	315	1SPZ*
27	3.94	80	315	1SPZ*
30	3.52	71	250	1SPZ*
34	3.12	80	250	1SPZ*
36	2.94	85	250	1SPZ*
38	2.78	90	250	1SPZ*
40	2.63	95	250	1SPZ*
42	2.50	100	250	1SPZ*
44	2.39	67	160	2SPZ
48	2.22	90	200	1SPZ*
50	2.11	95	200	1SPZ*
53	2.00	100	200	1SPZ*
57	1.87	75	140	2SPZ
59	1.79	112	200	1SPZ*
63	1.67	75	125	2SPZ
66	1.61	112	180	1SPZ*
70	1.51	106	160	1SPA*
73	1.44	125	180	1SPZ*
76	1.40	80	112	2SPZ
80	1.32	85	112	2SPZ
83	1.27	118	150	1SPA*
85	1.24	90	112	2SPZ
87	1.21	132	160	1SPA*
89	1.19	118	140	1SPA*
93	1.14	132	150	1SPA*
95	1.11	90	100	2SPZ
100	1.06	125	132	1SPA*
106	1.00	95	95	2SPZ
112	1.06	132	125	1SPA*
119	1.12	140	125	1SPA*
125	1.18	112	95	2SPZ
127	1.20	90	75	3SPZ
132	1.24	112	90	2SPZ
134	1.27	95	75	3SPZ
136	1.29	180	140	1SPA*
139	1.32	125	95	2SPZ
141	1.33	100	75	3SPZ
144	1.36	180	132	1SPA*
147	1.39	125	90	2SPZ
152	1.44	180	125	1SPA*
156	1.47	140	95	2SPZ
158	1.49	112	75	3SPZ
161	1.53	180	118	1SPA*
165	1.56	140	90	2SPZ
169	1.60	200	125	1SPA*
174	1.65	140	85	3SPZ
176	1.67	125	75	3SPZ
179	1.69	200	118	1SPA*

C 20:1

Nominal Output Speed	Pulley Ratio	Pulley Motor Dia (mm)	Gearbox	Number of Belts
10	7.04	71	500	2SPZ
11	6.25	80	500	2SPZ
12	5.97	67	400	1SPZ*
13	5.63	71	400	1SPZ*
15	4.70	67	315	1SPZ*
16	4.44	71	315	1SPZ*
17	4.20	75	315	1SPZ*
18	3.94	80	315	1SPZ*
19	3.73	67	250	1SPZ*
20	3.52	71	250	1SPZ*
21	3.33	75	250	1SPZ*
22	3.20	125	400	1SPZ*
23	3.12	80	250	1SPZ*
24	2.99	67	200	1SPZ*
25	2.82	71	200	1SPZ*
26	2.69	67	180	1SPZ*
28	2.54	71	180	1SPZ*
30	2.39	67	160	1SPZ*
31	2.25	71	160	1SPZ*
33	2.13	75	160	1SPZ*
34	2.09	67	140	2SPZ
36	1.97	71	140	1SPZ*
37	1.89	95	180	1SPZ*
38	1.87	75	140	1SPZ*
40	1.75	80	140	1SPZ*
41	1.70	106	180	1SPA
42	1.68	95	160	1SPZ*
43	1.65	85	140	1SPZ*
44	1.60	100	160	1SPZ*
45	1.56	80	125	1SPZ*
46	1.53	118	180	1SPA
47	1.50	100	150	1SPA
48	1.47	85	125	1SPZ*
49	1.44	125	180	1SPZ*
50	1.42	67	95	2SPZ
51	1.39	90	125	1SPZ*
52	1.34	67	90	2SPZ
53	1.33	75	100	2SPZ
54	1.32	95	125	1SPZ*
55	1.28	125	160	1SPZ*
56	1.27	67	85	2SPZ
57	1.24	90	112	1SPZ*
59	1.19	67	80	2SPZ
60	1.18	95	112	1SPZ*
62	1.14	140	160	1SPZ
63	1.12	67	75	2SPZ
66	1.07	75	80	2SPZ
67	1.06	71	75	2SPZ
70	1.00	100	100	1SPA
74	1.05	100	95	2SPZ

* Single belt drives can be used, however, two belts can also be used without overloading the SMSR input shaft bearings.

Shaft Mounted Speed Reducer

Wedge Belt Drives for 1440 rev/min Electric Motors

D 5:1

Nominal Output Speed	Pulley Ratio	Pulley Motor Dia (mm)	Gearbox	Number of Belts
51	5.62	112	630	1SPA*
54	5.26	95	500	2SPZ
60	4.77	132	630	1SPA*
64	4.46	112	500	1SPA*
67	4.24	118	500	1SPA*
75	3.79	132	500	1SPA*
82	3.50	90	315	3SPZ
86	3.32	95	315	3SPZ
91	3.15	100	315	2SPA
101	2.81	112	315	2SPZ
107	2.67	150	400	1SPA*
113	2.52	125	315	2SPZ
120	2.39	132	315	2SPA
128	2.23	112	250	2SPA
135	2.12	118	250	2SPA
143	2.00	100	200	3SPZ
151	1.89	106	200	3SPA
159	1.80	100	180	3SPZ
163	1.75	180	315	1SPA*
171	1.67	150	250	2SPA
178	1.61	112	180	3SPZ
181	1.57	200	315	1SPA*
187	1.53	118	180	2SPA
190	1.50	100	150	3SPA
200	1.43	112	160	3SPZ
204	1.40	100	140	3SPA
209	1.36	132	180	2SPA
216	1.32	106	140	3SPA
222	1.29	140	180	2SPA
228	1.25	112	140	3SPZ
235	1.21	132	160	2SPA
242	1.18	106	125	3SPA
250	1.14	140	160	2SPA
255	1.12	100	112	4SPZ
266	1.07	140	150	2SPA
269	1.06	118	125	3SPA
285	1.00	140	140	2SPA
301	1.05	118	112	3SPA
306	1.07	150	140	2SPA
317	1.11	100	90	5SPZ
324	1.14	150	132	3SPA
337	1.18	200	170	2SPB
342	1.20	180	150	2SPA
346	1.21	160	132	3SPA
356	1.25	250	200	1SPA*
365	1.28	160	125	3SPZ
375	1.32	125	95	5SPZ
380	1.33	200	150	2SPA
387	1.36	160	118	3SPA
396	1.39	125	90	5SPZ

D 13:1

Nominal Output Speed	Pulley Ratio	Pulley Motor Dia (mm)	Gearbox	Number of Belts
11	9.40	67	630	3SPZ
14	7.46	67	500	2SPZ
18	5.97	67	400	2SPZ
19	5.63	71	400	1SPZ*
21	5.00	80	400	1SPZ*
22	4.71	85	400	1SPZ*
25	4.21	95	400	1SPZ*
26	4.00	100	400	1SPZ*
28	3.73	67	250	2SPZ
30	3.50	90	315	1SPZ*
34	3.15	100	315	1SPZ*
36	2.97	106	315	1SPA*
38	2.82	71	200	2SPZ
40	2.67	75	200	2SPZ
42	2.50	100	250	1SPA*
44	2.40	75	180	2SPZ
47	2.25	80	180	2SPZ
50	2.12	85	180	2SPZ
53	2.00	90	180	2SPZ
56	1.89	95	180	2SPZ
60	1.78	90	160	2SPZ
63	1.68	95	160	2SPZ
64	1.65	85	140	3SPZ
66	1.60	125	200	1SPA*
70	1.52	132	200	1SPA*
71	1.50	100	150	2SPA
72	1.47	85	125	3SPZ
74	1.43	140	200	1SPA*
76	1.39	90	125	3SPZ
79	1.33	150	200	1SPA*
80	1.32	85	112	3SPZ
82	1.29	140	180	1SPA*
85	1.25	112	140	2SPZ
88	1.20	150	180	1SPA*
90	1.18	85	100	4SPZ
92	1.14	140	160	2SPZ
94	1.12	160	180	1SPA*
100	1.06	100	106	3SPA
101	1.05	112	118	2SPA
106	1.00	100	100	3SPZ
112	1.05	118	112	2SPA
118	1.11	200	180	1SPA*
120	1.14	150	132	2SPA
125	1.18	132	112	2SPA
127	1.20	150	125	2SPA
128	1.21	160	132	2SPA
132	1.25	200	160	1SPA*
135	1.27	150	118	2SPA
136	1.29	180	140	2SPA
139	1.32	125	95	3SPZ

D 20:1

Nominal Output Speed	Pulley Ratio	Pulley Motor Dia (mm)	Gearbox	Number of Belts
10	7.04	71	500	2SPZ
11	6.25	80	500	2SPZ
12	5.97	67	400	1SPZ*
13	5.63	71	400	1SPZ*
14	5.00	80	400	1SPZ*
15	4.70	67	315	1SPZ*
16	4.44	71	315	1SPZ*
17	4.20	75	315	1SPZ*
18	3.94	80	315	1SPZ*
19	3.73	67	250	1SPZ*
20	3.52	71	250	1SPZ*
21	3.33	75	250	1SPZ*
22	3.20	125	400	1SPZ*
23	3.12	80	250	1SPZ*
24	2.94	85	250	1SPZ*
25	2.78	90	250	1SPZ*
26	2.69	67	180	2SPZ
27	2.63	95	250	1SPZ*
28	2.50	100	250	1SPZ*
30	2.35	85	200	1SPZ*
32	2.22	90	200	1SPZ*
33	2.13	75	160	2SPZ
34	2.09	67	140	2SPZ
35	2.00	100	200	1SPZ*
37	1.89	95	180	1SPZ*
38	1.87	67	125	2SPZ
39	1.80	100	180	1SPZ*
40	1.75	80	140	2SPZ
41	1.70	106	180	1SPA*
42	1.67	75	125	2SPZ
44	1.61	112	180	1SPZ*
45	1.58	71	112	2SPZ
46	1.53	118	180	1SPA*
47	1.49	75	112	2SPZ
49	1.44	125	180	1SPZ*
50	1.40	80	112	2SPZ
51	1.39	90	125	2SPZ
52	1.34	67	90	3SPZ
53	1.32	106	140	1SPA*
55	1.28	125	160	1SPZ*
56	1.27	67	85	3SPZ
58	1.21	132	160	1SPA*
59	1.20	125	150	1SPA*
60	1.18	85	100	2SPZ
62	1.14	140	160	1SPZ*
63	1.11	90	100	2SPZ
66	1.07	140	150	1SPA
67	1.06	90	95	2SPZ
70	1.00	125	125	1SPA
74	1.06	132	125	1SPA

* Single belt drives can be used, however, two belts can also be used without overloading the SMSR input shaft bearings.

Shaft Mounted Speed Reducer

Wedge Belt Drives for 1440 rev/min Electric Motors

E 5:1

Nominal Output Speed	Pulley Ratio	Pulley Motor Dia (mm)	Gearbox	Number of Belts
51	5.56	90	500	3SPZ
54	5.26	95	500	3SPZ
60	4.77	132	630	2SPA
63	4.50	140	630	1SPA*
68	4.20	150	630	1SPA*
73	3.94	160	630	1SPA*
80	3.57	112	400	2SPA
84	3.39	118	400	2SPA
89	3.20	125	400	2SPA
96	2.97	106	315	3SPA
101	2.81	112	315	3SPZ
107	2.67	150	400	2SPA
113	2.52	125	315	3SPZ
120	2.39	132	315	2SPA
127	2.25	140	315	2SPA
136	2.11	95	200	5SPZ
143	2.00	100	200	4SPA
151	1.89	95	180	5SPZ
160	1.79	112	200	4SPZ
168	1.70	106	180	4SPA
173	1.65	170	280	2SPB
178	1.60	125	200	3SPA
183	1.56	160	250	2SPA
189	1.51	106	160	4SPA
198	1.44	125	180	4SPZ
204	1.40	160	224	2SPB
209	1.36	132	180	3SPA
214	1.33	150	200	3SPA
223	1.28	125	160	3SPA
228	1.25	200	250	2SPA
235	1.21	132	160	3SPA
240	1.19	118	140	4SPA
250	1.14	140	160	4SPZ
254	1.12	160	180	2SPB
257	1.11	180	200	2SPA
266	1.07	140	150	3SPA
270	1.06	125	132	4SPA
285	1.00	125	125	5SPZ
301	1.05	118	112	5SPA
304	1.07	160	150	3SPA
317	1.11	200	180	2SPA
324	1.14	150	132	4SPA
336	1.18	200	170	2SPB
342	1.20	180	150	2SPA
356	1.25	212	170	2SPB
365	1.28	160	125	5SPZ
376	1.32	224	170	2SPB
380	1.33	200	150	3SPA
387	1.36	160	118	4SPA
396	1.39	250	180	2SPA

E 13:1

Nominal Output Speed	Pulley Ratio	Pulley Motor Dia (mm)	Gearbox	Number of Belts
11	9.40	67	630	3SPZ
13	8.40	75	630	3SPZ
14	7.46	67	500	2SPZ
16	6.67	75	500	2SPZ
18	5.97	67	400	2SPZ
19	5.63	71	400	2SPZ
21	5.00	100	500	1SPA*
24	4.44	71	315	2SPZ
25	4.20	75	315	2SPZ
26	4.00	100	400	1SPA*
28	3.77	106	400	1SPA*
31	3.39	118	400	1SPA*
33	3.20	125	400	1SPA*
35	3.03	132	400	1SPA*
36	2.94	85	250	2SPZ
38	2.78	90	250	2SPZ
40	2.63	95	250	2SPZ
42	2.52	125	315	1SPA*
44	2.39	132	315	1SPA*
45	2.35	85	200	3SPZ
47	2.25	80	180	3SPZ
50	2.12	85	180	3SPZ
53	2.00	100	200	2SPA
55	1.89	95	180	3SPZ
56	1.89	106	200	2SPA
59	1.79	112	200	2SPA
60	1.75	180	315	1SPA*
62	1.70	106	180	2SPA
65	1.61	112	180	2SPA
66	1.60	100	160	3SPZ
69	1.53	118	180	2SPA
71	1.50	100	150	3SPA
73	1.44	125	180	2SPA
74	1.43	140	200	2SPZ
76	1.39	180	250	1SPA*
78	1.36	132	180	2SPA
79	1.34	112	150	3SPA
80	1.32	100	132	3SPA
82	1.29	140	180	2SPA
83	1.28	125	160	2SPA
85	1.25	200	250	1SPA*
87	1.21	132	160	2SPA
89	1.18	112	132	3SPA
90	1.18	170	200	2SPB
93	1.14	140	160	2SPA
95	1.12	125	140	3SPZ
99	1.07	140	150	2SPA
100	1.06	100	106	4SPA
101	1.05	95	100	5SPZ
106	1.00	112	112	4SPZ

E 20:1

Nominal Output Speed	Pulley Ratio	Pulley Motor Dia (mm)	Gearbox	Number of Belts
10	7.04	71	500	2SPZ
11	6.25	80	500	2SPZ
12	5.97	67	400	1SPZ*
13	5.63	71	400	1SPZ*
14	5.00	80	400	1SPZ*
15	4.71	85	400	1SPZ*
16	4.44	90	400	1SPZ*
17	4.21	95	400	1SPZ*
18	4.00	100	400	1SPZ*
19	3.71	85	315	1SPZ*
20	3.52	71	250	2SPZ
21	3.32	95	315	1SPZ*
22	3.15	100	315	1SPZ*
23	3.12	80	250	2SPZ
24	2.99	67	200	2SPZ
25	2.82	71	200	2SPZ
26	2.67	75	200	2SPZ
28	2.54	71	180	2SPZ
29	2.40	75	180	2SPZ
30	2.35	85	200	2SPZ
31	2.25	80	180	2SPZ
33	2.13	75	160	3SPZ
34	2.09	67	140	3SPZ
35	2.00	80	160	2SPZ
37	1.88	85	160	2SPZ
38	1.87	67	125	3SPZ
39	1.79	112	200	1SPA*
40	1.75	180	315	1SPA*
42	1.69	118	200	1SPA*
43	1.65	85	140	3SPZ
44	1.60	125	200	1SPA*
45	1.56	160	250	1SPA*
46	1.53	118	180	2SPA
47	1.52	132	200	1SPA*
48	1.47	95	140	2SPZ
49	1.44	125	180	1SPA*
50	1.40	100	140	2SPZ
52	1.36	132	180	1SPA*
53	1.33	150	200	1SPA*
54	1.32	95	125	3SPZ
55	1.27	118	150	2SPA
56	1.25	100	125	2SPA
58	1.21	132	160	2SPA
59	1.20	150	180	1SPA*
60	1.18	106	125	2SPA
62	1.14	140	160	2SPZ
63	1.11	90	100	3SPZ
66	1.07	140	150	2SPA
67	1.06	106	112	2SPA
70	1.00	160	160	1SPA*

* Single belt drives can be used, however, two belts can also be used without overloading the SMSR input shaft bearings.

Shaft Mounted Speed Reducer

Wedge Belt Drives for 1440 rev/min Electric Motors

F 5:1

Nominal Output Speed	Pulley Ratio	Pulley Motor Dia (mm)	Gearbox	Number of Belts
50	5.71	140	800	3SPZ
57	5.00	100	500	3SPA
61	4.72	106	500	3SPA
68	4.21	95	400	5SPZ
73	3.94	160	630	2SPA
77	3.71	170	630	2SPB
82	3.50	180	630	2SPB
86	3.32	95	315	6SPZ
91	3.15	100	315	5SPZ
97	2.94	170	500	2SPB
103	2.78	180	500	2SPA
108	2.63	190	500	2SPB
113	2.52	125	315	4SPZ
121	2.35	170	400	2SPB
127	2.25	140	315	4SPZ
135	2.12	118	250	4SPA
143	2.00	125	250	5SPZ
151	1.89	132	250	4SPA
160	1.79	140	250	5SPZ
168	1.69	118	200	5SPA
173	1.65	170	280	2SPB
178	1.60	125	200	4SPA
181	1.56	160	250	2SPB
187	1.53	118	180	5SPA
192	1.49	212	315	2SPB
200	1.43	140	200	5SPZ
205	1.39	180	250	2SPB
215	1.32	160	212	3SPB
222	1.29	140	180	4SPA
226	1.26	250	315	2SPB
235	1.21	132	160	5SPA
242	1.18	190	224	2SPB
250	1.14	140	160	6SPZ
255	1.12	200	224	2SPB
267	1.07	150	160	4SPA
271	1.05	224	236	2SPB
285	1.00	224	224	2SPB
301	1.06	224	212	2SPB
304	1.07	160	150	4SPA
317	1.11	200	180	3SPA
324	1.14	150	132	5SPA
336	1.18	200	170	3SPB
342	1.20	180	150	4SPA
356	1.25	212	170	3SPB
360	1.26	315	250	2SPB
365	1.28	160	125	6SPA
376	1.32	224	170	3SPB
380	1.33	200	150	4SPA
387	1.36	160	118	6SPA
396	1.39	250	180	3SPA

F 13:1

Nominal Output Speed	Pulley Ratio	Pulley Motor Dia (mm)	Gearbox	Number of Belts
10	10.67	75	800	3SPZ
11	9.40	67	630	3SPZ
13	8.40	75	630	3SPZ
14	7.46	67	500	2SPZ
15	7.04	71	500	2SPZ
17	6.30	100	630	1SPA*
19	5.62	112	630	1SPA*
21	5.04	125	630	1SPA*
24	4.44	90	400	2SPZ
25	4.24	118	500	1SPA*
26	4.00	125	500	1SPA*
28	3.79	132	500	1SPA*
30	3.57	140	500	1SPA*
32	3.33	150	500	1SPA*
34	3.15	100	315	2SPA
36	2.97	106	315	2SPA
38	2.81	112	315	2SPA
39	2.67	118	315	2SPA
40	2.63	190	500	2SPB
42	2.50	100	250	3SPZ
45	2.36	106	250	3SPA
47	2.25	140	315	2SPZ
48	2.22	180	400	1SPA*
50	2.12	118	250	2SPA
53	2.00	100	200	3SPA
55	1.89	132	250	2SPA
56	1.89	106	200	3SPA
58	1.80	100	180	4SPZ
60	1.75	180	315	2SPA
63	1.68	95	160	5SPZ
66	1.61	112	180	3SPA
68	1.56	160	250	2SPA
69	1.53	118	180	3SPA
71	1.50	100	150	4SPA
74	1.44	125	180	4SPZ
76	1.40	100	140	5SPZ
78	1.36	132	180	3SPA
80	1.32	160	212	2SPB
81	1.32	170	224	2SPB
83	1.28	125	160	3SPA
85	1.25	160	200	2SPA
88	1.21	132	160	3SPA
89	1.19	118	140	4SPA
90	1.18	170	200	2SPB
93	1.14	132	150	3SPA
95	1.12	118	132	4SPA
99	1.06	160	170	2SPB
100	1.06	118	125	4SPA
106	1.00	140	140	4SPZ
112	1.06	170	160	2SPB

F 20:1

Nominal Output Speed	Pulley Ratio	Pulley Motor Dia (mm)	Gearbox	Number of Belts
10	7.04	71	500	2SPZ
11	6.67	75	500	2SPZ
12	5.97	67	400	2SPZ
13	5.63	71	400	2SPZ
14	5.00	80	400	2SPZ
15	4.70	67	315	2SPZ
16	4.44	71	315	2SPZ
17	4.20	75	315	2SPZ
18	4.00	100	400	1SPA*
19	3.77	106	400	1SPA*
20	3.57	112	400	1SPA*
21	3.39	118	400	1SPA*
22	3.20	125	400	1SPZ*
23	3.03	132	400	1SPA*
24	2.94	85	250	2SPZ
25	2.86	140	400	1SPZ*
26	2.67	118	315	1SPA*
27	2.63"	95	250	2SPZ
28	2.50	80	200	3SPZ
29	2.40	75	180	3SPZ
30	2.39	132	315	1SPA*
31	2.25	80	180	3SPZ
33	2.17	85	180	3SPZ
35	2.00	100	200	2SPA
36	1.97	160	315	1SPA*
37	1.88	85	160	3SPZ
39	1.79	112	200	2SPZ
40	1.75	80	140	4SPZ
42	1.70	106	180	2SPA
43	1.65	85	140	4SPZ
44	1.60	125	200	2SPZ
45	1.56	160	250	1SPA*
46	1.53	118	180	2SPA
47	1.50	100	150	3SPA
48	1.48	160	236	2SPB
49	1.43	112	160	2SPA
50	1.40	100	140	3SPZ
51	1.39	180	250	1SPA*
52	1.36	118	160	2SPA
53	1.32	100	132	3SPA
55	1.29	140	180	2SPZ
56	1.25	100	125	3SPA
58	1.21	132	160	2SPA
59	1.20	125	150	2SPA
60	1.18	106	125	3SPA
62	1.14	132	150	2SPA
63	1.11	106	118	3SPA
66	1.06	132	140	2SPA
67	1.05	112	118	3SPA
70	1.00	200	200	2SPA

* Single belt drives can be used, however, two belts can also be used without overloading the SMSR input shaft bearings.

Shaft Mounted Speed Reducer

Wedge Belt Drives for 1440 rev/min Electric Motors

G 5:1

Nominal Output Speed	Pulley Ratio	Pulley Motor	Dia (mm) Gearbox	Number of Belts
51	5.62	112	630	3SPA
54	5.26	95	500	5SPZ
60	4.77	132	630	3SPA
63	4.50	140	630	4SPZ
67	4.24	118	500	4SPA
71	4.00	125	500	5SPZ
77	3.71	170	630	2SPB
84	3.39	118	400	5SPA
89	3.20	125	400	6SPZ
94	3.03	132	400	4SPA
101	2.81	224	630	2SPB
107	2.67	150	400	4SPA
114	2.50	160	400	2SPB
121	2.36	212	500	2SPB
127	2.25	140	315	5SPA
136	2.10	150	315	5SPA
143	2.00	200	400	3SPA
151	1.89	212	400	3SPB
160	1.79	140	250	6SPA
163	1.75	180	315	3SPB
168	1.69	236	400	2SPB
172	1.66	190	315	3SPB
178	1.60	250	400	2SPB
183	1.56	180	280	3SPB
190	1.50	236	355	3SPB
192	1.49	212	315	3SPB
200	1.43	140	200	6SPA
206	1.39	170	236	4SPB
214	1.33	150	200	6SPA
225	1.27	280	355	2SPB
228	1.25	200	250	3SPB
238	1.20	250	300	3SPC
242	1.18	200	236	3SPB
252	1.13	265	300	3SPC
256	1.11	212	236	3SPB
266	1.07	280	300	3SPC
270	1.06	212	224	3SPB
285	1.00	224	224	3SPB
301	1.05	236	224	3SPB
306	1.07	300	280	3SPC
317	1.11	200	180	4SPB
322	1.13	355	315	2SPB
336	1.18	200	170	5SPB
341	1.20	335	280	3SPC
355	1.24	224	180	4SPB
359	1.26	315	250	2SPB
374	1.31	236	180	4SPB
381	1.33	315	236	3SPB
396	1.39	250	180	5SPA
399	1.40	224	160	5SPB

G 13:1

Nominal Output Speed	Pulley Ratio	Pulley Motor	Dia (mm) Gearbox	Number of Belts
11	9.40	67	630	3SPZ
12	8.87	71	630	3SPZ
13	8.40	75	630	3SPZ
14	7.41	85	630	3SPZ
15	7.04	71	500	3SPZ
16	6.63	95	630	3SPZ
17	6.30	100	630	2SPA
18	5.88	85	500	3SPZ
19	5.62	112	630	3SPZ
20	5.26	95	500	3SPZ
21	5.00	80	400	3SPZ
22	4.77	132	630	2SPA
23	4.72	106	500	2SPA
24	4.46	112	500	2SPZ
25	4.21	95	400	3SPZ
27	4.00	125	500	2SPZ
28	3.77	106	400	2SPA
30	3.57	140	500	2SPZ
31	3.39	118	400	2SPA
33	3.20	125	400	2SPA
34	3.15	100	315	3SPA
36	2.97	106	315	3SPA
38	2.81	112	315	3SPZ
40	2.63	95	250	5SPZ
42	2.50	100	250	4SPZ
44	2.39	132	315	2SPA
45	2.36	106	250	3SPA
47	2.25	140	315	2SPA
50	2.11	95	200	5SPZ
53	2.00	100	200	4SPA
56	1.89	132	250	3SPA
57	1.85	170	315	2SPB
59	1.79	140	250	4SPZ
61	1.75	180	315	2SPA
63	1.69	118	200	4SPA
64	1.65	170	280	2SPB
66	1.60	125	200	5SPZ
70	1.53	118	180	4SPA
72	1.48	160	236	2SPB
74	1.43	140	200	3SPA
76	1.39	170	236	2SPB
80	1.33	150	200	3SPA
83	1.27	118	150	5SPA
85	1.24	180	224	2SPB
87	1.21	132	160	4SPA
90	1.18	180	212	2SPB
93	1.14	140	160	4SPA
95	1.11	180	200	3SPA
100	1.06	212	224	2SPB

G 20:1

Nominal Output Speed	Pulley Ratio	Pulley Motor	Dia (mm) Gearbox	Number of Belts
10	7.04	71	500	2SPZ
11	6.25	80	500	2SPZ
12	5.97	67	400	3SPZ
13	5.33	75	400	3SPZ
14	5.00	80	400	2SPZ
15	4.71	85	400	2SPZ
16	4.44	90	400	2SPZ
17	4.21	95	400	2SPZ
18	4.00	100	400	2SPZ
19	3.71	85	315	3SPZ
20	3.57	112	400	2SPZ
21	3.33	150	500	2SPA
22	3.20	125	400	2SPZ
23	3.03	132	400	2SPA
24	2.94	85	250	3SPZ
25	2.78	90	250	3SPZ
26	2.67	150	400	1SPA*
27	2.63	95	250	3SPZ
28	2.52	125	315	2SPZ
30	2.36	106	250	3SPA
31	2.25	140	315	2SPZ
32	2.23	112	250	2SPA
33	2.12	118	250	2SPA
34	2.10	150	315	2SPA
35	2.00	100	200	3SPA
36	1.97	160	315	2SPA
37	1.89	95	180	4SPZ
39	1.80	100	180	4SPZ
40	1.75	180	315	2SPA
41	1.70	106	180	3SPA
42	1.67	150	250	2SPA
44	1.60	125	200	3SPZ
45	1.56	160	250	2SPA
47	1.50	100	150	4SPA
48	1.47	95	140	5SPZ
49	1.43	112	160	4SPZ
50	1.40	100	140	4SPA
51	1.39	180	250	2SPA
52	1.36	118	160	3SPA
53	1.33	150	200	2SPA
55	1.28	125	160	3SPA
56	1.25	160	200	2SPA
58	1.21	132	160	3SPA
59	1.20	125	150	3SPA
60	1.18	170	200	2SPB
62	1.14	132	150	3SPA
63	1.11	180	200	2SPA
66	1.07	140	150	3SPA
67	1.05	190	200	2SPB
70	1.00	180	180	2SPB

* Single belt drives can be used, however, two belts can also be used without overloading the SMSR input shaft bearings.

Shaft Mounted Speed Reducer

Wedge Belt Drives for 1440 rev/min Electric Motors

H 5:1

Nominal Output Speed	Pulley Ratio	Pulley Motor Dia (mm)	Gearbox	Number of Belts
50	5.71	140	800	5SPZ
54	5.26	190	1000	3SPB
60	4.77	132	630	5SPA
63	4.50	140	630	4SPA
71	4.00	200	800	3SPA
82	3.50	180	630	3SPA
86	3.32	190	630	3SPB
91	3.15	200	630	3SPA
96	2.97	212	630	3SPB
101	2.81	224	630	3SPB
107	2.67	150	400	6SPA
113	2.52	250	630	2SPB
121	2.35	170	400	4SPB
127	2.25	280	630	2SPB
136	2.11	190	400	4SPB
142	2.01	236	475	3SPC
145	1.97	160	315	6SPA
150	1.91	236	450	3SPC
160	1.79	224	400	3SPB
163	1.75	180	315	4SPB
168	1.69	236	400	3SPB
172	1.66	190	315	4SPB
178	1.60	265	425	3SPC
181	1.57	200	315	5SPA
188	1.52	280	425	3SPC
192	1.49	212	315	4SPB
200	1.43	280	400	3SPB
211	1.35	315	425	3SPC
216	1.32	212	280	4SPB
225	1.27	315	400	2SPB
228	1.25	224	280	3SPC
238	1.20	250	300	3SPC
242	1.18	212	250	4SPB
252	1.13	265	300	3SPC
256	1.11	212	236	5SPB
266	1.07	280	300	3SPC
271	1.05	224	236	4SPB
285	1.00	200	200	5SPB
300	1.05	315	300	3SPC
306	1.07	300	280	3SPC
317	1.11	200	180	6SPB
323	1.13	300	265	3SPC
336	1.18	212	180	6SPB
341	1.20	335	280	3SPC
357	1.25	250	200	6SPA
362	1.27	355	280	3SPB
375	1.32	250	190	5SPB
381	1.33	315	236	3SPC
396	1.39	250	180	6SPB
399	1.40	280	200	5SPB

H 13:1

Nominal Output Speed	Pulley Ratio	Pulley Motor Dia (mm)	Gearbox	Number of Belts
10	10.67	75	800	3SPZ
11	9.41	85	800	3SPZ
12	8.89	90	800	3SPZ
13	8.42	95	800	3SPZ
14	7.87	80	630	3SPZ
16	6.63	95	630	3SPZ
18	5.94	106	630	2SPA
19	5.62	112	630	2SPA
21	5.00	100	500	3SPA
23	4.72	106	500	3SPA
25	4.21	95	400	5SPZ
27	4.00	100	400	4SPZ
28	3.77	106	400	4SPA
30	3.57	140	500	2SPA
32	3.33	150	500	2SPA
34	3.15	100	315	5SPZ
35	3.03	132	400	3SPA
37	2.86	140	400	4SPZ
38	2.78	180	500	2SPA
40	2.67	118	315	4SPA
42	2.50	160	400	2SPB
44	2.39	132	315	4SPA
45	2.35	170	400	2SPB
47	2.25	140	315	5SPZ
48	2.22	180	400	2SPB
50	2.10	150	315	3SPA
51	2.09	170	355	2SPB
54	1.97	160	315	2SPB
56	1.89	132	250	4SPA
57	1.87	190	355	2SPB
59	1.79	140	250	4SPA
61	1.75	180	315	2SPB
64	1.66	190	315	2SPB
66	1.60	250	400	2SPB
68	1.56	160	250	3SPB
72	1.48	160	236	3SPB
74	1.43	140	200	5SPA
76	1.39	180	250	3SPB
79	1.33	236	315	2SPB
80	1.33	150	200	5SPA
82	1.29	140	180	5SPA
85	1.25	224	280	2SPB
90	1.18	180	212	3SPB
95	1.11	180	200	4SPA
100	1.06	212	224	3SPB

H 20:1

Nominal Output Speed	Pulley Ratio	Pulley Motor Dia (mm)	Gearbox	Number of Belts
10	7.04	71	500	3SPZ
11	6.63	95	630	3SPZ
12	5.88	85	500	3SPZ
13	5.56	90	500	3SPZ
14	5.04	125	630	2SPA
15	4.71	85	400	3SPZ
16	4.44	90	400	3SPZ
17	4.24	118	500	2SPA
18	4.00	125	500	2SPZ
19	3.77	106	400	3SPA
20	3.57	112	400	2SPA
21	3.39	118	400	2SPA
22	3.20	125	400	2SPA
23	3.03	132	400	2SPA
24	2.97	106	315	3SPA
25	2.86	140	400	2SPA
26	2.67	150	400	2SPA
27	2.63	95	250	5SPZ
28	2.52	125	315	4SPZ
30	2.36	106	250	4SPA
31	2.25	140	315	3SPZ
32	2.23	112	250	4SPZ
33	2.12	118	250	3SPA
34	2.10	150	315	2SPA
35	2.00	125	250	3SPA
36	1.97	160	315	2SPA
37	1.89	132	250	3SPA
38	1.85	170	315	2SPB
39	1.79	140	250	4SPZ
40	1.75	180	315	2SPA
41	1.70	106	180	5SPA
42	1.69	118	200	4SPA
44	1.60	125	200	5SPZ
45	1.57	200	315	2SPA
47	1.52	132	200	4SPA
48	1.47	170	250	2SPB
49	1.44	125	180	4SPA
51	1.39	170	236	2SPB
52	1.36	132	180	4SPA
53	1.33	150	200	3SPA
54	1.31	180	236	2SPB
55	1.27	118	150	5SPA
57	1.24	180	224	2SPB
59	1.20	125	150	5SPA
60	1.18	190	224	2SPB

Shaft Mounted Speed Reducer

Wedge Belt Drives for 1440 rev/min Electric Motors

J 5:1

Nominal Output Speed	Pulley Ratio	Pulley Motor Dia (mm)	Gearbox	Number of Belts
51	5.56	180	1000	3SPB
54	5.26	190	1000	3SPB
57	5.00	160	800	4SPB
61	4.71	170	800	4SPB
63	4.50	140	630	6SPA
68	4.21	190	800	4SPB
71	4.00	200	800	5SPA
76	3.77	212	800	4SPB
80	3.57	224	800	3SPB
84	3.39	236	800	3SPB
89	3.20	250	800	3SPB
96	2.97	212	630	4SPB
100	2.86	280	800	3SPB
107	2.67	236	630	4SPB
112	2.54	315	800	3SPB
120	2.38	265	630	3SPC
127	2.24	250	560	3SPC
134	2.13	375	800	3SPC
143	2.00	250	500	4SPB
150	1.90	250	475	3SPC
159	1.79	265	475	3SPC
168	1.70	280	475	3SPC
171	1.67	300	500	3SPC
178	1.60	265	425	3SPC
181	1.57	400	630	3SPC
189	1.51	315	475	3SPC
201	1.42	250	355	4SPC
203	1.41	355	500	3SPC
211	1.35	315	425	3SPC
215	1.32	400	530	3SPC
225	1.27	315	400	4SPB
228	1.25	300	375	3SPC
238	1.20	375	450	3SPC
241	1.18	300	355	3SPC
252	1.13	265	300	4SPC
255	1.12	335	375	3SPC
266	1.07	280	300	4SPC
269	1.06	335	355	3SPC
285	1.00	280	280	4SPC
300	1.05	315	300	4SPC
302	1.06	355	335	3SPC
306	1.07	300	280	4SPC
319	1.12	375	335	3SPC
338	1.18	355	300	4SPC
341	1.19	400	335	3SPC
357	1.25	375	300	4SPC
360	1.26	315	250	5SPC
362	1.27	400	315	3SPC
381	1.33	315	236	5SPC
382	1.34	355	265	4SPC

J 13:1

Nominal Output Speed	Pulley Ratio	Pulley Motor Dia (mm)	Gearbox	Number of Belts
11	10.00	100	1000	3SPA
12	8.89	90	800	4SPZ
13	8.00	100	800	3SPA
14	7.55	106	800	3SPA
15	7.14	112	800	3SPA
16	6.63	95	630	5SPZ
17	6.40	125	800	3SPZ
18	5.94	106	630	4SPA
19	5.62	112	630	3SPA
21	5.04	125	630	4SPZ
22	4.77	132	630	3SPA
23	4.72	106	500	4SPA
24	4.50	140	630	4SPZ
25	4.24	118	500	4SPA
27	3.94	160	630	2SPB
29	3.71	170	630	2SPB
30	3.57	140	150	4SPA
32	3.33	150	500	3SPA
34	3.12	160	500	3SPA
35	3.03	132	400	4SPA
37	2.86	140	400	4SPA
38	2.78	180	500	3SPA
40	2.63	190	500	2SPB
42	2.50	160	400	3SPB
44	2.39	132	315	5SPA
45	2.36	212	500	2SPB
47	2.25	355	800	3SPB
48	2.22	180	400	3SPB
50	2.12	224	475	3SPC
51	2.09	170	355	3SPB
53	2.00	200	400	3SPA
54	1.97	160	315	4SPB
56	1.90	224	425	3SPC
57	1.87	190	355	3SPB
59	1.79	140	250	6SPA
61	1.75	180	315	4SPA
64	1.66	190	315	3SPB
67	1.57	200	315	4SPA
68	1.56	180	280	4SPB
71	1.49	212	315	3SPB
72	1.47	170	250	5SPB
74	1.43	280	400	2SPB
76	1.39	180	250	5SPA
79	1.33	236	315	3SPB
81	1.32	190	250	4SPB
83	1.27	315	400	2SPB
85	1.24	190	236	4SPB
89	1.19	236	280	3SPB
95	1.12	250	280	3SPB
100	1.06	212	224	4SPB

J 20:1

Nominal Output Speed	Pulley Ratio	Pulley Motor Dia (mm)	Gearbox	Number of Belts
10	7.00	90	630	3SPZ
11	6.30	100	630	3SPZ
12	5.94	106	630	3SPA
13	5.62	112	630	3SPZ
14	5.00	100	500	3SPA
15	4.72	106	500	3SPA
16	4.50	140	630	2SPA
17	4.21	95	400	5SPZ
18	4.00	100	400	4SPA
19	3.77	106	400	4SPA
20	3.57	140	500	3SPZ
21	3.39	118	400	3SPA
22	3.20	125	400	3SPA
23	3.03	132	400	3SPA
24	2.94	170	500	2SPB
25	2.78	180	500	2SPA
26	2.67	118	315	4SPA
27	2.63	190	500	2SPB
28	2.52	125	315	5SPZ
30	2.35	170	400	2SPB
31	2.25	140	315	5SPZ
32	2.22	180	400	2SPB
33	2.12	118	250	5SPA
34	2.09	170	355	3SPB
35	2.01	236	475	3SPC
36	1.97	160	315	3SPA
37	1.91	236	450	3SPC
38	1.87	190	355	2SPB
39	1.79	140	250	4SPA
40	1.75	180	315	3SPA
41	1.70	250	425	3SPC
42	1.67	150	250	4SPA
43	1.65	170	280	3SPB
44	1.60	125	200	6SPA
45	1.57	200	315	3SPA
47	1.49	212	315	2SPB
48	1.47	190	280	3SPB
49	1.43	140	200	5SPA
51	1.39	170	236	3SPB
53	1.33	150	200	5SPA
54	1.31	180	236	3SPB
55	1.29	140	180	6SPA
56	1.25	200	250	4SPA
57	1.24	190	236	3SPB
59	1.19	160	190	4SPB
60	1.18	200	236	3SPB
63	1.12	160	180	5SPA
66	1.06	236	250	3SPB
67	1.06	170	180	4SPB
70	1.00	280	280	2SPB

All dimensions in millimetres unless otherwise stated. Every effort has been taken to ensure that the data listed in this catalogue is correct. Challenge accepts no liability for any inaccuracies or damage caused.

Shaft Mounted Speed Reducer

Wedge Belt Drives for 1440 rev/min Electric Motors

S 20:1

Nominal Output Speed	Pulley Ratio	Pulley Motor Dia (mm)	Dia (mm) Gearbox	Number of Belts
10	7.14	112	800	3SPA
12	5.94	106	630	4SPA
14	5.04	125	630	4SPA
16	4.46	112	500	4SPA
18	3.94	160	630	3SPA
22	3.20	125	400	5SPA
24	2.94	170	500	3SPB
26	2.67	150	400	4SPA
28	2.50	160	400	4SPB
30	2.37	150	355	4SPB
32	2.22	180	400	4SPA
34	1.97	160	315	4SPB
38	1.87	190	355	4SPB
40	1.75	180	315	4SPB
42	1.66	190	315	4SPB
46	1.50	236	355	3SPB
50	1.40	200	280	4SPB
52	1.33	236	315	3SPC
54	1.31	180	236	5SPB
58	1.20	250	300	3SPC
62	1.13	265	300	3SPC
66	1.07	280	300	3SPC

K 20:1

Nominal Output Speed	Pulley Ratio	Pulley Motor Dia (mm)	Dia (mm) Gearbox	Number of Belts
10	7.14	140	1000	3SPB
12	6.06	132	800	4SPA
14	5.00	160	800	3SPB
16	4.44	180	800	3SPB
18	3.94	160	630	4SPB
22	3.29	170	560	4SPB
24	2.97	212	630	3SPB
26	2.81	224	630	3SPB
28	2.52	250	630	3SPB
30	2.36	212	500	3SPB
32	2.23	224	500	3SPB
34	2.00	200	400	4SPB
38	1.89	212	400	4SPB
40	1.80	236	425	3SPC
42	1.70	250	425	3SPC
46	1.59	236	375	3SPC
50	1.42	250	355	3SPC
52	1.41	224	315	4SPC
54	1.34	250	335	3SPC
58	1.25	300	375	3SPC
62	1.18	300	355	3SPC
66	1.12	335	375	3SPC

L 20:1

Nominal Output Speed	Pulley Ratio	Pulley Motor Dia (mm)	Dia (mm) Gearbox	Number of Belts
10	7.14	140	1000	4SPB
12	6.25	160	1000	3SPB
14	5.26	190	1000	3SPB
16	4.46	224	1000	3SPB
18	4.00	200	800	3SPB
22	3.34	190	630	4SPB
24	3.02	265	800	3SPC
26	2.81	224	630	3SPC
28	2.64	212	560	5SPB
30	2.50	224	560	5SPB
32	2.25	280	630	4SPB
34	2.12	236	500	5SPB
38	1.91	236	450	5SPC
40	1.87	300	560	4SPC
42	1.77	300	530	4SPC
46	1.60	250	400	4SPC
50	1.48	425	630	3SPC
52	1.40	400	560	3SPC
54	1.35	315	425	4SPC
58	1.27	315	400	4SPC
62	1.19	315	375	4SPC
66	1.12	335	375	4SPC

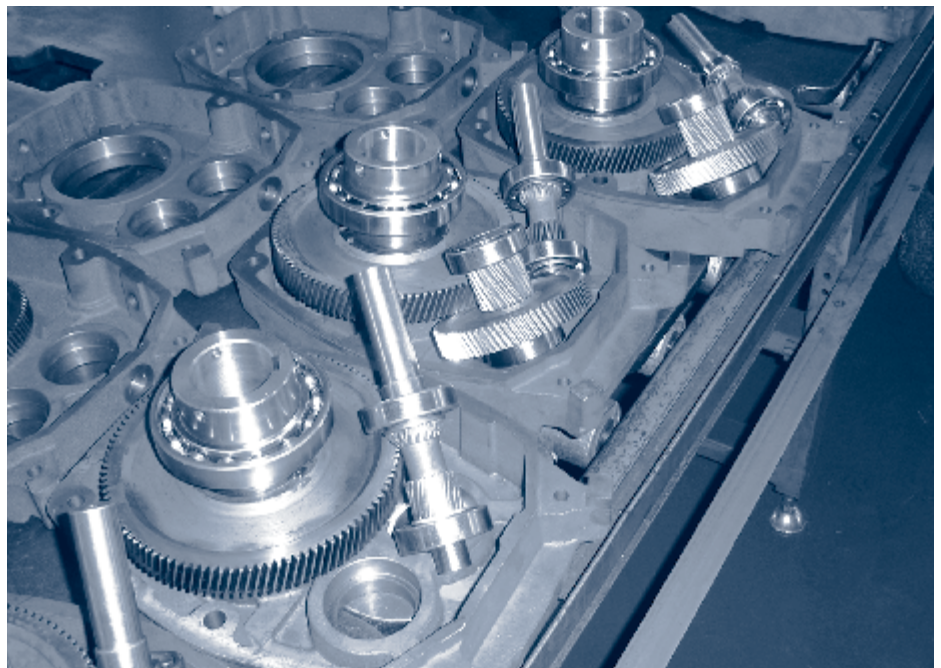

Shaft Mounted Speed Reducer

SMSR Dimensions

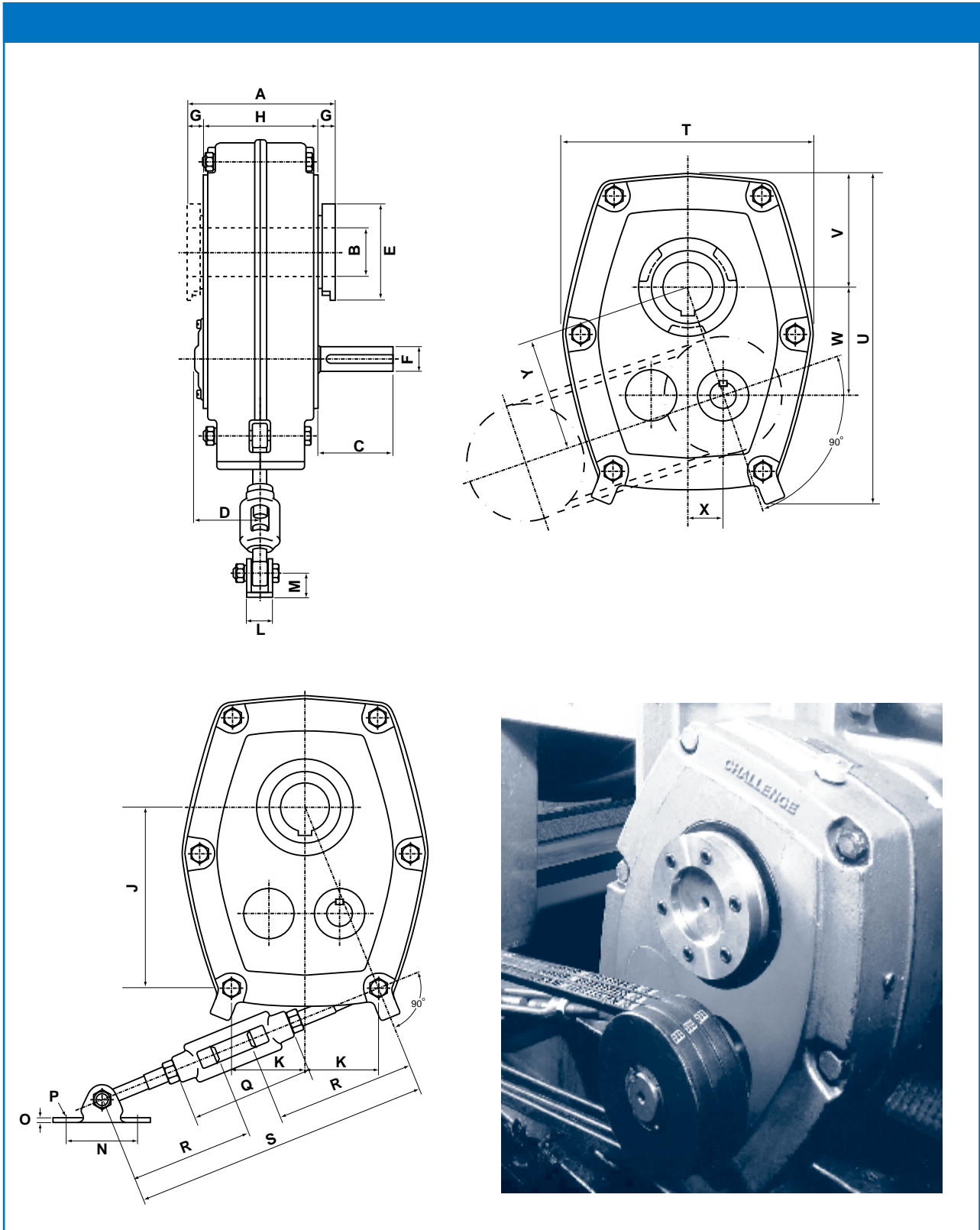

Note: for flange mounting positions-consult CHALLENGE

Shaft Mounted Speed Reducer

SMSR Dimensions Table

		SMSR Dimensions										
		B	C	D	E	F	G	H	J	S	K	L
A		134	142	152	170	189	212	242	257	290	310	356
B		30	40	50	55	65	75	85	100	120	125	150
Output hub key		8 x 7	12 x 8	14 x 9	16 x 10	18 x 11	20 x 12	22 x 14	28 x 16	32 x 18	32 x 18	36 x 20
C		63	72	77	85	90	105	116	135	145	186	216
D		59	65	68	76	87	110	115	119	123	196	203
E		80	90	100	115	130	145	170	200	186	218	238
F		19	22	25	28	32	42	48	55	55	60	65
Input shaft keyway		6x3.5x50	6x3.5x59	8x4x63	8x4x70	10x5x70	12x5x90	14x5.5x95	16x6x100	16x6x100	18x7x110	18x7x110
G		15	17	17	20	20	20	26	30	35	44	44
H		104	108	118	130	149	172	190	197	220	222	268
J		131	156	88	222	242	277	330	424	456	513	590
K		55	59	76	90	98	110	88	102	157	102	160
L		24	24	28	28	34	34	70	70	70	70	110
M		20	20	24	24	30	30	50	50	50	51	76
N		65	65	75	75	100	100	120	120	120	120	180
O		5	5	5	5	6	6	18	18	18	18	26
P		10	10	12	12	16	16	16	16	16	M16	M24
Q		200	200	216	216	216	216	222	222	222	222	265
R		300	300	350	350	375	375	375	375	375	375	400
S	Min	600	600	700	700	750	750	750	750	750	750	775
	Max	750	750	850	850	900	900	900	900	900	900	925
T		186	218	258	278	317	365	434	542	542	643	770
U		241	282	338	386	419	475	550	700	734	841	1000
V		81	96	117	129	143	162	195	254	254	298	370
W		75	90	110	125	141	156	189	255	255	280	324
X		25	31	37	43	50	56	62	75	75	100	119
Y		79	95	116	133	150	166	200	266	266	297	345
Weight-kgf	single reduction	19	25	34	45	59	88	139	202	-	-	-
	double reduction	20	26	36	50	64	98	150	216	380	411	714
Exact Gear Ratios												
Nominal	5:1	5.050	5.050	5.047	5.047	5.047	5.047	5.047	5.047	-	-	-
Ratios	13:1	13.984	13.596	13.589	13.589	13.589	13.589	13.589	13.589	-	-	-
	20:1	20.456	20.456	20.456	20.456	20.456	20.456	20.456	20.456	20.455	19.970	19.580

Every effort has been taken to ensure that the data listed in this catalogue is correct. Challenge accepts no liability for any inaccuracies or damage caused. All dimensions in millimetres unless otherwise stated.

Shaft Mounted Speed Reducer

Standard Hub Bores

SMSR	Bore in Standard Hub	Additional Bores using Reducing Bushes
B	30	25
C	40	35, 32, 30
D	50	45, 42, 40, 38
E	55	50, 45, 42
F	65	60, 55, 50
G	75	70, 65, 60
H	85	80, 75, 70
J	100	95, 90
S	120	110, 100, 90
K	125	110, 100, 90
L	150	130, 125, 100

Alternative Hub Bores (Maximum)

SMSR	Bore in Alternative Hub	Additional Bores using Reducing Bushes
B	40	35
C	50	45
D	55	-
E	65	60
F	75	70
G	85	80
H	100	95, 90
J	120	110, 115

Standard hub bores are machined to F7 limits and a h7 tolerance is recommended for the shaft.

Keyways for standard output hubs and reducing bushes are machined to BS 4235. The shaft keyway should be machined in accordance with the Table below.

Shaft ϕ	Key	Shaft ϕ	Key	Shaft ϕ	Key	Shaft ϕ	Key
30	8 x 7	45	14 x 9	75	20 x 12	110	28 x 16
32	10 x 8	50	14 x 9	80	22 x 14	120	32 x 18
35	10 x 8	55	16 x 10	85	22 x 14	125	32 x 18
38	10 x 8	60	18 x 11	90	25 x 14	130	32 x 18
40	12 x 8	65	18 x 11	95	25 x 14	140	36 x 20
42	12 x 8	70	20 x 12	100	28 x 16	150	36 x 20

Challenge Reducing Bush Locking System

Keys are supplied when reduction bushes are used. Usually two keys are supplied, but for thin walled bushes, a single stepped key will be supplied.

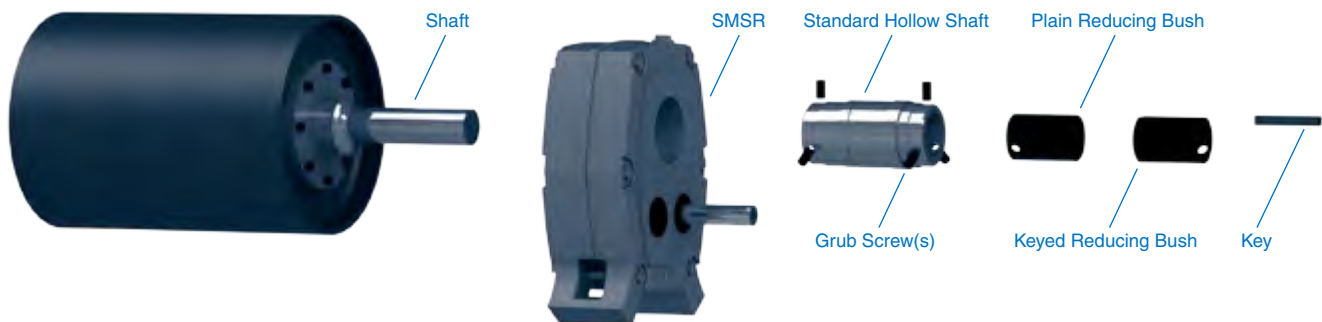

Procedure for Assembly

Step 1: Insert the keyed and plain reducing bushes into the hollow shaft.



Step 2: Mount gearbox with reducing bushes onto the driven shaft and insert key.

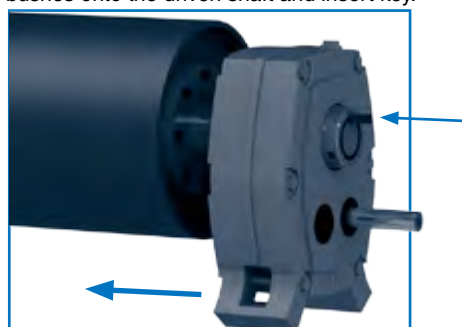

Step 3: Tighten grub screws on collar sequentially.

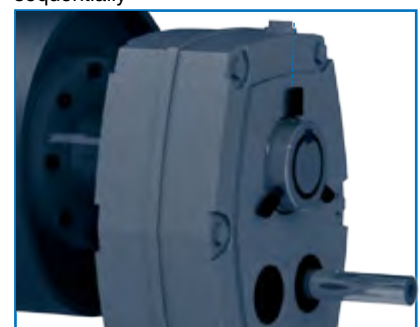

All dimensions in millimetres unless otherwise stated. Every effort has been taken to ensure that the data listed in this catalogue is correct. Challenge accepts no liability for any inaccuracies or damage caused.

Shaft Mounted Speed Reducer

Challenge Grip-Loc Locking System



Advantages

- Has sufficient torque transmitting ability to avoid the need for conventional shaft keys
- Reversible assembly
- Obviates problems caused by the usual operating environment and atmospheric conditions
- By virtue of the design, Grip-Loc prevents the onset of fretting corrosion, which often causes problems with more conventional mounting systems
- Much more simple to install and remove than keyed assemblies
- Fits standard shafts with h11 tolerances

Grip-Loc Bush Bores

SMSR	Available Bores
B	20,25,30
C	30,35,40
D	40,45,50
E	45,50,55
F	55,60,65
G	65,70,75
H	75,80,85
J	90,95,100
S	120
K	125
L	150

Procedure for Assembly

- 1) Screw Grip-Loc Bush (clockwise) into Grip-Loc Hub.
- 2) Mount on driven shaft to the required position.
- 3) Tighten cap head screws sequentially (which draws the bush against its opposing taper and locks solid against the shaft).

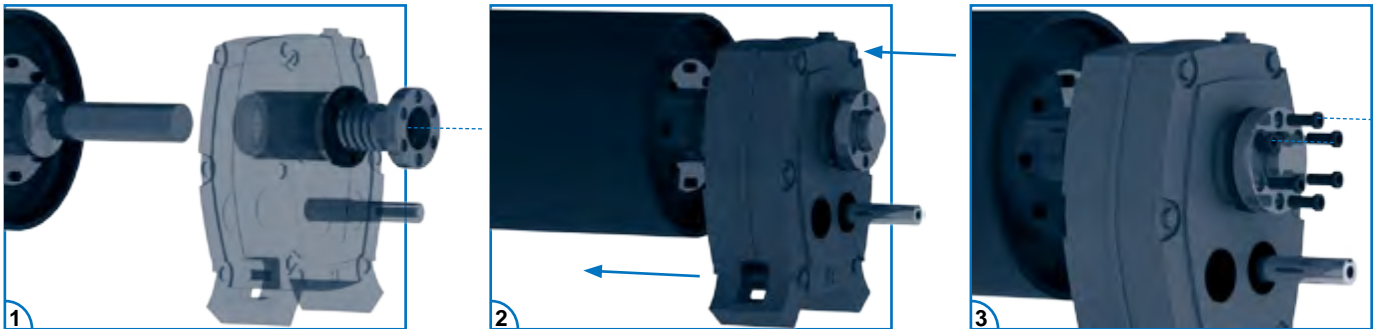

Procedure for Removal

This is a much simpler operation compared to the “hollow shaft” speed reducers that utilise parallel keys.

Many Shaft Mounted Speed Reducer applications are subject to poor operating conditions, such as in quarries etc. When the time comes to remove the SMSR from the shaft, a build up of corrosion can become a major problem and make the disassembly difficult.

As the Grip-Loc hub and shaft are of dissimilar metals, fretting corrosion is not a problem. Therefore, when the Grip-Loc screws are loosened and the tapers part, sufficient clearance is created for the Grip-Loc bush and speed reducer to be easily removed from the shaft.

Safety

Once a Grip-Loc hub has been correctly installed, there is no possibility for the taper to “break” and thus allow the speed reducer to move on the shaft.

The installation and removal screws play no part in holding the taper grip and even their removal would not adversely affect the performance of Grip-Loc.

Shaft Mounted Speed Reducer

SMSR Output Hub Options

SIZE	GEARBOXES WITH STANDARD OUTPUT HUBS			GEARBOXES WITH ALTERNATE OUTPUT HUBS			GEARBOXES WITH GRIP-LOC OUTPUT HUBS		
	Boxes with Standard Output Hubs (bore in mm)	Reducing bushes available from stock	Reducing bushes - outer diameter reduce to inner diameter	Boxes with Standard Output Hubs (bore in mm)	Reducing bushes available from stock	Reducing bushes - outer diameter reduce to inner diameter	Boxes with Grip-Loc Output Hubs	Grip-Loc Bushes available from stock	Grip-Loc Bushes - bore size
B	B5 (30)	1	30mm to 25mm	B13AB (40)	1	40mm to 35mm	B5GL	3	30mm 25mm 20mm
	B13 (30)			B20AB (40)			B13GL		
	B20 (30)						B20GL		
C	C5 (40)	3	40mm to 35mm 40mm to 32mm 40mm to 30mm	C5AB (50)	1	50mm to 45mm	C5GL	3	40mm 35mm 30mm
	C13 (40)			C13AB (50)			C13GL		
	C20 (40)			C20AB (50)			C20GL		
D	D5 (50)	4	50mm to 45mm 50mm to 42mm 50mm to 40mm 50mm to 38mm	D5AB (55)	0		D5GL	3	50mm 45mm 40mm
	D13 (50)			D13AB (55)			D13GL		
	D20 (50)			D20AB (55)			D20GL		
E	E5 (55)	3	55mm to 50mm 55mm to 45mm 55mm to 42mm	E5AB (65)	1	65mm to 60mm	E5GL	3	55mm 50mm 45mm
	E13 (55)			E13AB (65)			E13GL		
	E20 (55)			E20AB (65)			E20GL		
F	F5 (65)	3	65mm to 60mm 65mm to 55mm 65mm to 50mm	F5AB (75)	1	75mm to 70mm	F5GL	3	65mm 60mm 55mm
	F13 (65)			F13AB (75)			F13GL		
	F20 (65)			F20AB (75)			F20GL		
G	G5 (75)	3	75mm to 70mm 75mm to 65mm 75mm to 60mm	G5AB (85)	1	85mm to 80mm	G5GL	3	75mm 70mm 65mm
	G13 (75)			G13AB (85)			G13GL		
	G20 (75)			G20AB (85)			G20GL		
H	H5 (85)	3	85mm to 80mm 85mm to 75mm 85mm to 70mm	H5AB (100)	2	100mm to 95mm 100mm to 90mm	H5GL	3	85mm 80mm 75mm
	H13 (85)			H13AB (100)			H13GL		
	H20 (85)			H20AB (100)			H20GL		
J	J5 (100)	2	100mm to 95mm 100mm to 90mm	J5AB (120)	2	120mm to 115mm 120mm to 110mm	J5GL	4	100mm 95mm 90mm 85mm
	J13 (100)			J13AB (120)			J13GL		
	J20 (100)			J20AB (120)			J20GL		

All dimensions in millimetres unless otherwise stated. Every effort has been taken to ensure that the data listed in this catalogue is correct. Challenge accepts no liability for any inaccuracies or damage caused.

Shaft Mounted Speed Reducer

SMSR Installation

Satisfactory performance depends on correct installation, lubrication and maintenance. Therefore it is important that the instructions in the installation leaflet are followed carefully.

1. Prepare driven shaft by removing key and ensuring surface is clean, smooth and free from burrs. Coat shaft with "Anti Seize Compound".
2. Align reducer hub and shaft keyway then gently slide the reducer on to the driven shaft. Mount the reducer as close to driven shaft bearing as possible to reduce the overhung load. If possible the end of the driven shaft should be level with the outer edge of reducer output hub.
3. Fit the drive key to protrude at least one third way into length of hub keyway and flush with outer edge of reducer hub.
4. The hub clamp can now be tightened.

The Challenge SMSR creates little, if any, axial load on the shaft necessitating only light clamping to locate the unit on to the driven shaft.

5. Install pulley on gearbox input shaft as close to the reducer as possible. Failure to do this will cause excessive loads in the input shaft bearings and could cause their premature failure.
6. Install motor and belt drive with the belt pull at approximately 90° to the centre line between driven and input shafts. This will permit tensioning of the belt drive with the torque arm. The torque arm itself should work in tension. If output hub runs anti-clockwise, the torque arm should be positioned to the right.
7. Install torque-arm fulcrum on a rigid support so that the torque arm will be at approximately right angles to the centre line through the driven shaft and the torque-arm case bolt.
8. Make sure there is sufficient take up in the turn-buckle for belt tension adjustment.

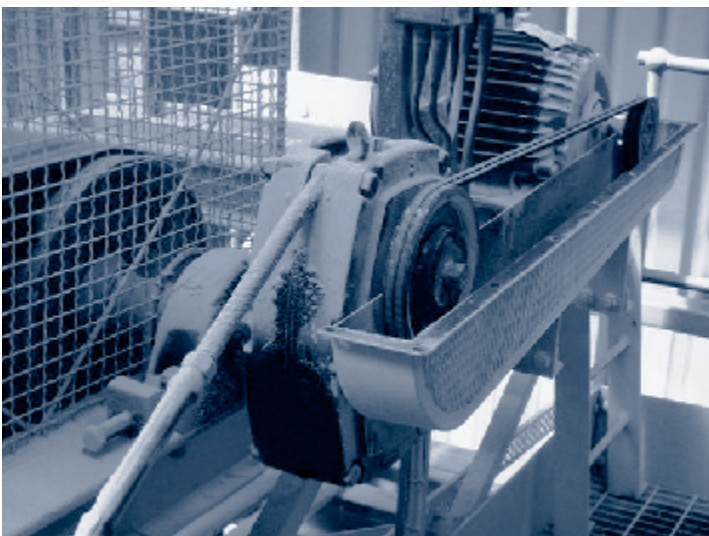
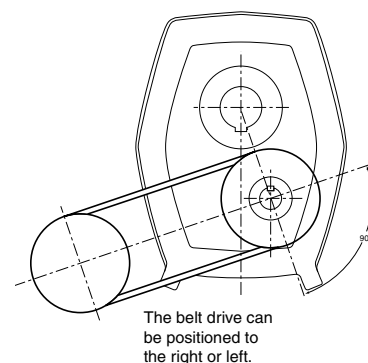
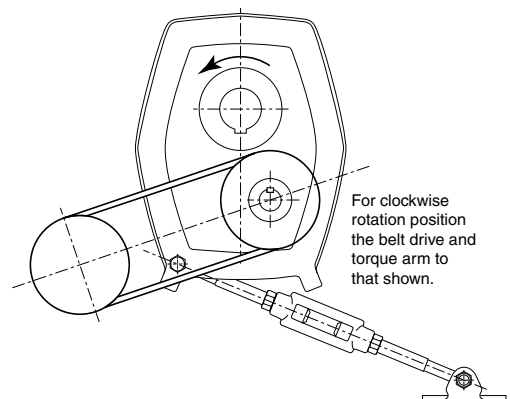
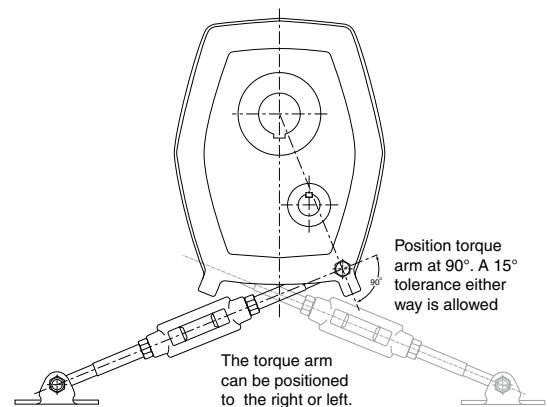
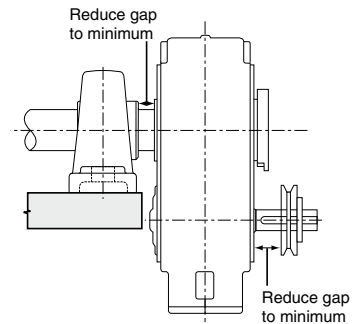

Shaft Mounted Speed Reducer

Lubrication

Units are supplied without oil and should be filled before running with a recommended lubricant to the correct level dependant on the mounting position.

Remove the taper plugs from the filler/breather and level positions as shown in the diagram.

Fill until the lubricant overflows the oil level aperture. Replace the level taper plug.

For output speeds below 10 rev/min, consult Challenge.

Fit the filler/breather plug (supplied loose).

Synthetic Lubricants

Certain approved synthetic lubricants are suitable for use in gear units - consult your lubricant supplier

Recommended oil change periods

The first change should be after 2500 hours and thereafter every 8000 hours of running or two years.

If the temperature exceeds 70°C, then oil changes should be every 6 months.

If the application is subject to frequent stops/starts, oil changes should be more frequent.

It is also recommended that the breather plug should be changed with every oil change.

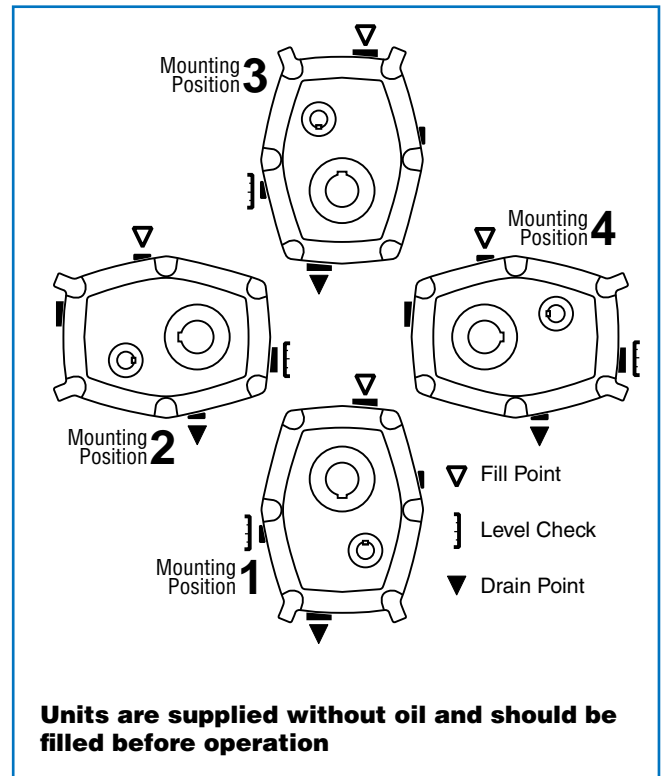

Lubricant Capacity

SMSR Size	Capacity (Litres)							
	5:1				13:1 & 20:1			
	Mounting Position				Mounting Position			
	1	2	3	4	1	2	3	4
B	0.4	0.4	0.4	0.5	0.3	0.5	0.4	0.5
C	0.6	0.7	0.6	0.8	0.8	1.5	1.2	1.3
D	1.0	1.4	1.2	1.5	0.8	1.5	1.2	1.3
E	1.9	2.0	1.8	1.9	1.7	2.0	1.8	1.6
F	2.6	2.5	2.5	2.6	2.3	2.5	2.5	2.5
G	3.3	4.1	3.3	4.6	3.0	4.3	3.4	3.9
H	4.8	7.1	5.0	7.1	4.5	7.0	5.0	6.9
J	9.3	16.0	12.0	16.0	7.5	14.0	11.0	13.0
S	-	-	-	-	9.1	16.4	12.6	15.4
K	-	-	-	-	12.5	13.5	24.0	11.5
L	-	-	-	-	22.5	34.0	52.0	27.0

Mineral Oil ISO Viscosity Grade

Unit Ratio	5:1				13:1 & 20:1						
	0 - 100	101 - 200	201 - 400		0 - 20	21 - 50		51 - 120		0 - 50	51 - 80
SMSR Size	BCDE	BCDE	BC	DEFGHJ	BCDEF	BCD	EFGHJS	BCD	EFGHJS	K L	K L
Amb Temp °C	FGHJ	FGHJ	BC	DEFGHJ	GHJS	BCD	EFGHJS	BCD	EFGHJS	K L	K L
-10 to +5	100	100	100	68	150	150	150	100	100	100	100
+6 to +25	460	320	320	220	680	680	460	460	320	320	220
+26 to +40	800	680	380	460	800	800	800	680	460	460	320

Note: Do not use Extreme Pressure (E.P.) mineral oils when using a backstop.

Every effort has been taken to ensure that the data listed in this catalogue is correct. Challenge accepts no liability for any inaccuracies or damage caused.

Shaft Mounted Speed Reducer

Backstops

Note: Challenge do not recommend the use of backstops on 5:1 units as this affects the units power ratings. Should this be necessary please contact the Challenge Technical Department.

IMPORTANT - Direction of Shaft Rotation

Care should be taken to ensure that the backstop is installed correctly for the required shaft rotation direction. Incorrect installation will cause damage to the internal gears when power from the motor is applied.

With the arrow facing AWAY from the reducer, the direction of the free shaft rotation is as follows:

Type 1 and Type 1 (a)

An arrow on the OUTER RACE indicates the internal sprag gears free rotation direction. The shaft will therefore rotate in the opposite direction.

i.e. arrow marking **clockwise** on the outer race indicates that the shafts free rotation direction is **anti-clockwise**.

Type 2

These units include an inner race. An arrow marked on this INNER RACE indicates the inner race's free rotation direction and therefore the shafts free rotation direction.

i.e. arrow marking **clockwise** on the inner race indicates that the shafts free rotation direction is **clockwise**.

If you require the shaft to rotate in the opposite direction, turn the backstop around so that the side which has an arrow faces the reducer.

Installation

If the reducer is filled with oil, drain off the oil before proceeding.

Step 1: Remove the backstop cover and gasket from the reducer body.

Step 2: Determine the required direction of shaft rotation.

Locate the backstop into the housing. Feed the key into the backstop outer race and housing keyways. In the case of backstops with an inner race, feed another key into the backstop's inner race and the shaft keyways and install the circlips on the shaft groove.

Step 3: Install the backstop cover with a new gasket

Step 4: Refill the reducer with the correct quantity and grade of oil.

CAUTION: When pressing the backstop into the housing, do NOT use a hammer. The backstop may be tapped gently if necessary with a soft mallet.

Type 1



SMSR: B, C, D, E, F

Type 2



SMSR: G, H, J

Type 1 (a)

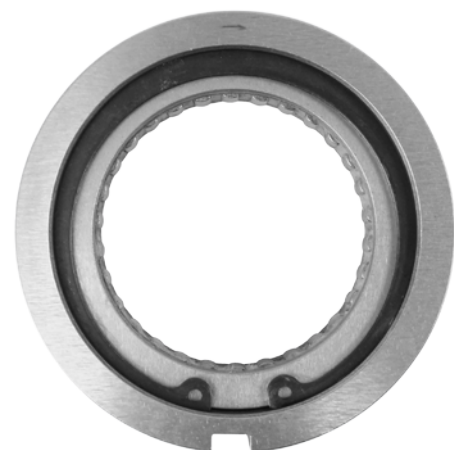

SMSR: S, K, L

Shaft Mounted Speed Reducer

Maintenance Parts Product Codes

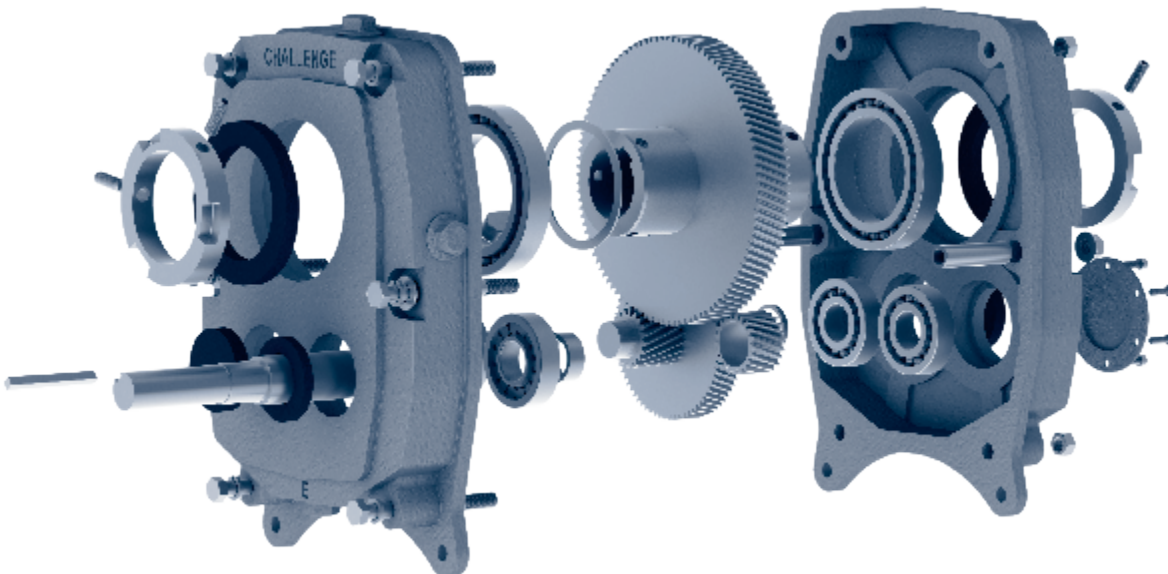
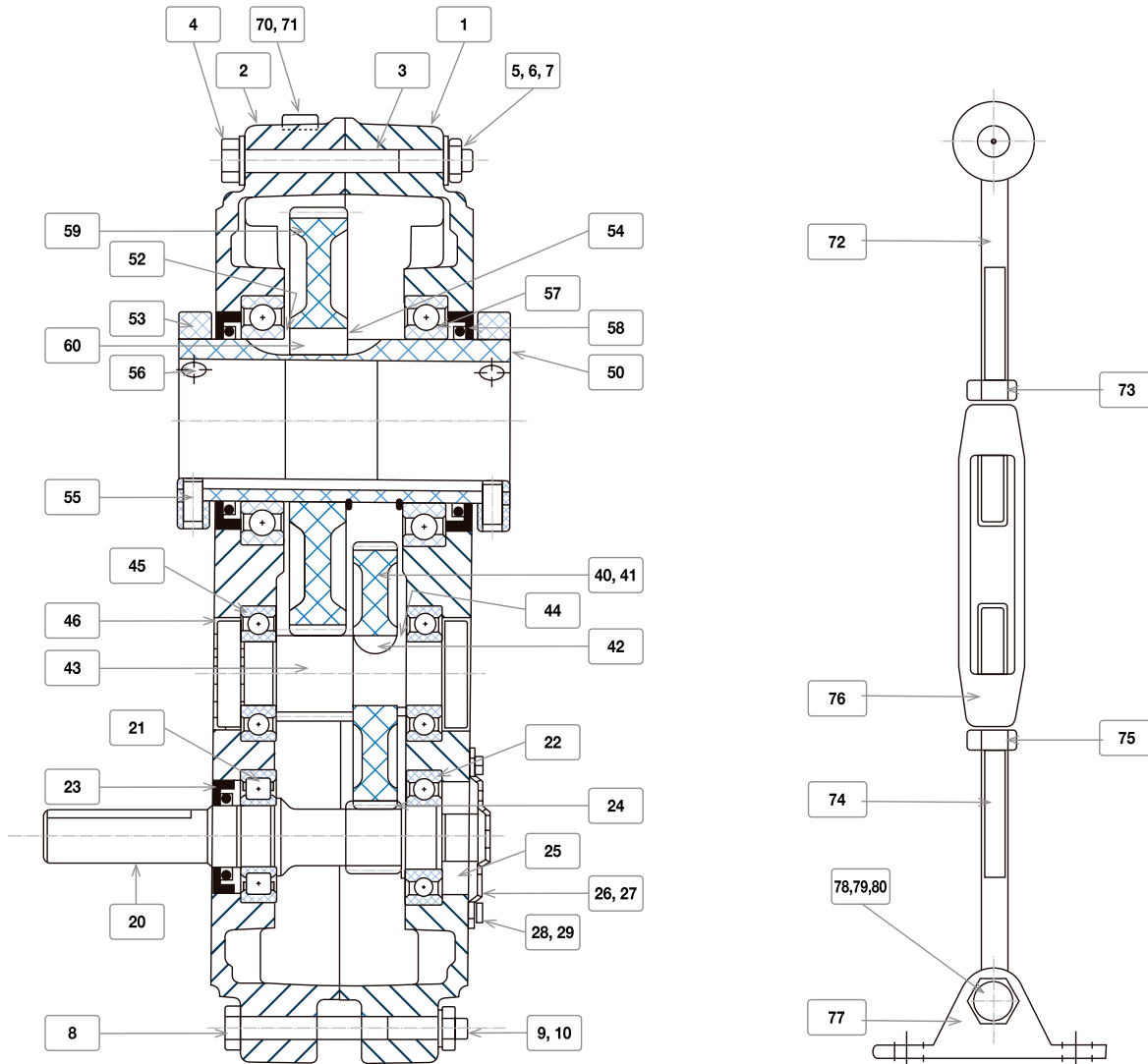

Every effort has been taken to ensure that the data listed in this catalogue is correct. Challenge accepts no liability for any inaccuracies or damage caused.

Shaft Mounted Speed Reducer

Maintenance Parts Product Codes

drawing number	description	number required	B	C	D	E	F	G	H	J	S	K	L
1	Case (right hand)	1	B6002	C6002	D6002	E6002	F6002	G6002	H6002	J6002	S6002	K6002	L6002
2	Case (left hand)	1	B6003	C6003	D6003	E6003	F6003	G6003	H6003	J6003	S6003	K6003	L6003
3	Hollow dowel	2	B7004	C7004	D7004	E7004	F7004	G7004	H7004	J7004	S7004	K7004	L7004
4	Case bolt	6	B943702	C943830	D943831	E943840	F943850	G943851	H943841	J943842	S943842	K943842	L943842
5	Case nut	6	B943810	C943811-1	D943811	E943812-1	F943813-1	G943813-1	H943812	J943812	S943812	K943812	L943812
6	Case plain washer	4	B913820	C943821	D943821	E943822	F943823	G843823	H943822	J943822	S943822	K943822	L943822
7	Case lock washer	6	B943870	C943871	D943871	E943872	F943973	G943873	H943872	J943872	S943872	K943872	L943872
8	Torque arm case bolt	2	-	-	-	-	-	-	H943852	J943852	S943852	K943852	L943852
9	Torque arm case bolt nut	2	-	-	-	-	-	-	H943813-1	J943813-1	S943813-1	K943813-1	L943813-1
10	Torque arm case bolt lock washer	2	-	-	-	-	-	-	H943864	J943864	S943864	K943864	L943864
20	Input shaft and pinion (5:1) *	1	B6128	C6120	D6120	E6128	F6120	G6120	H6120	J6120	S6120	K6120	L6120
20	Input shaft and pinion (13:1)	1	B6108	C6100	D6100	E6109	F6100	G6100	H6100	J6100	S6100	K6100	L6100
20	Input shaft and pinion (20:1)	1	B6118	C6110	D6110	E6119	F6110	G6110	H6110	J6110	S6110	K6110	L6110
21	Input shaft bearing-shaft side	1	BNJ204EC	CNJ205EC	DNJ206EC	ENJ306EC	FNJ307EC	GNJ309EC	HNJ310EC	JNJ312EC	SNJ312EC	KNJ312EC	LNJ312EC
22	Input shaft bearing-backtop side	1	B6303	C6205	D6206	E6306	F6307	G6309	H6310	J6312	S6312	K6312	L6312
23	Input shaft oil seal	1	B946043	C946301	D946302	E946443	F946303	G946304	H946305	J946022	S946022	K946022	L946022
24	Input shaft spacer	1	B6050	C6050	D6050	E6050	F6050	G6050	H6050	J6050	S6050	K6050	L6050
25	Backstop	1†	B-B.Stop	C-B.Stop	D-B.Stop	E-B.Stop	F-B.Stop	G-B.Stop	H-B.Stop	J-B.Stop	S-B.Stop	K-B.Stop	L-B.Stop
26	Backstop cover	1	B7012	C7012	D7012	E7012	F6012	G6012	H6012	J6012	S6012	K6012	L6012
27	Backstop cover gasket	1	B7013	C7013	D7013	E7013	F7013	G7013	H7013	J7013	S7013	K7013	L7013
28	Backstop cover screw	6	B943480	C943480	D943490	E943490	F943490	G943690	H943690	J943690	S943690	K943690	L943690
29	Backstop cover lockwasher	6	B943686	C943686	D943687	E943687	F943687	G943680	H943680	J943680	S943680	K943680	L943680
40	1st reduction gear (13:1)	1	B6101	C6101	D6101	E6101	F6101	G6101	H6101	J6101	S6101	K6101	L6101
41	1st reduction gear (20:1)	1	B6111	C6111	D6111	E6111	F6111	G6111	H6111	J6111	S6111	K6111	L6111
42	1st reduction gear key	1	B7021	C7021	D7021	E7021	F7021	G7021	H7021	J7021	S7021	K7021	L7021
43	Intermediate pinion (13:1 & 20:1)	1	B6022	C6022	D6022	E6022	F6022	G6022-1	H6022	J6022	S6022	K6022	L6022
44	Intermediate pinion distance piece	1	B6023	C6023	D6023	E6023	F6023	G6023	H6023	J6023	S6023	K6023	L6023
45	Intermediate bearing (13:1, 20:1)	2	B6303	C6205	D6206	E6306	F6307	G6309	H6310	J6312	S6312	K6312	L6312
46	Intermediate cover	2	B7025	C7025	D7025	E7025	F7025	G7025	H7025	J7025	S7025	K7025	L7025
50	Output hub (standard hub bore)	1	B6105	C6105	D6105	E6105	F6105	G6105	H6105	J6105	S6105	K6105	L6105
50	Output hub (alternative hub bore-upper)	1	B6106	C6106	D6106	E6106	F6106	G6106	H6106	J6106	S6106	K6106	L6106
52	Output hub spacer	1	B6030	C6030	D6030	E6030	F6030	G6030	H6030	J6030-1	S6030-1	K6030-1	L6030-1
53	Output hub collar	2	B6031	C6031	D6031	E6031	F6031	G6031	H6031	J6031	S6031	K6031	L6031
54	Output hub circlip	2	B944187	C944188	D944189	E944190	F944191	G944192	-	-	-	-	-
55	Collar screw (standard hub) over key	1	B942614-1	C942700-1	D942700-1	E942711-1	F942711	G942711-1	H942721-1	J942722-1	S942722-1	K942722-1	L942722-1
56	Collar screw (standard hub) over shaft	1	B942615	C942701	D942701-1	E942712	F942713	G942713	H942724	J942724	S942724	K942724	L942724
55	Collar screw (alternative hub-upper) over key	1	B942614-2	C942700-2	D942700-2	E942710	F942710	G942711-2	H942721-2	J942721	S942721	K942721	L942721
56	Collar screw (alternative hub-upper) over shaft	1	B942614-3	C942700-3	D942701-2	E942711-2	F942712	G942712	H942722	J942722-2	S942722-2	K942722-2	L942722-2
57	Output hub bearing	2	B6011	C6013	D6015	E6017	F6020	G6022	H6026	J6030	S6030	K6030	L6030
58	Output hub oilseal	2	B946306	C946307	D946308	E946309	F946310	G946311	H946312	J946313	S946313	K946313	L946313
59	Output hub reduction gear	1	B6026	C6026	D6026	E6026	F6026	G6026	H6026-1	J6026	S6026	K6026	L6026
60	Output hub reduction gear key	1	B6027	C6027	D6027	E6027	F6027	G6027	H6027	J6027	S6027	K6027	L6027
70	Pipe plug	4#	B942395	C942395	D942395	E942395	F942395	G942396	H942396	J942396	S942396	K942396	L942396
71	Breather plug	1#	B946097	C946097	D946097	E946097	F946097	G946098	H946098	J946098	S946098	K946098	L946098
72	Torque arm rod end	1	B7041	C7041	D7041	E7041	F7041	G7041	H7041	J7041	S7041	K7041	L7041
73	Torque arm rod end locknut	1	B943812	C943812	D943813	E943813	F943815	G943815	H943816	J943816	S943816	K943816	L943816
74	Torque arm extension	1	B7043	C7043	D7043	E7043	F7043	G7043	H7043	J7043	S7043	K7043	L7043
75	Torque arm extension locknut	1	B943790	C943790	D943791	E943791	F943792	G943792	H943793	J943793	S943793	K943793	L943793
76	Turnbuckle	1	B7045	C7045	D7045	E7045	F7045	G7045	H7045	J7045	S7045	K7045	L7045
77	Fulcrum	1	B6046	C6046	D6046	E6046	F6046	G6046	H6046	J6046	S6046	K6046	L6046
78	Torque arm fulcrum bolt	1	B943832	C943832	D943843	E943843	F943854	G943854	H943855	J943855	S943855	K943855	L943855
79	Torque arm fulcrum bolt nut	1	B943811	C943811-2	D943812	E943812-2	F943813-2	G943813-2	H943813-2	J943813-2	S943813-2	K943813-2	L943813-2
80	Torque arm fulcrum bolt lockwasher	1	B943682	C943682	D943683	E943683	F943684	G943684	H943684	J943684	S943684	K943684	L943684

Note: Challenge do not recommend the use of backstops on 5:1 units as this effects the units power ratings. Should this be necessary please contact the Challenge Technical Department.

† if required

can be positioned to suit

Note

Shaft Mounted Speed Reducers

TXT Range

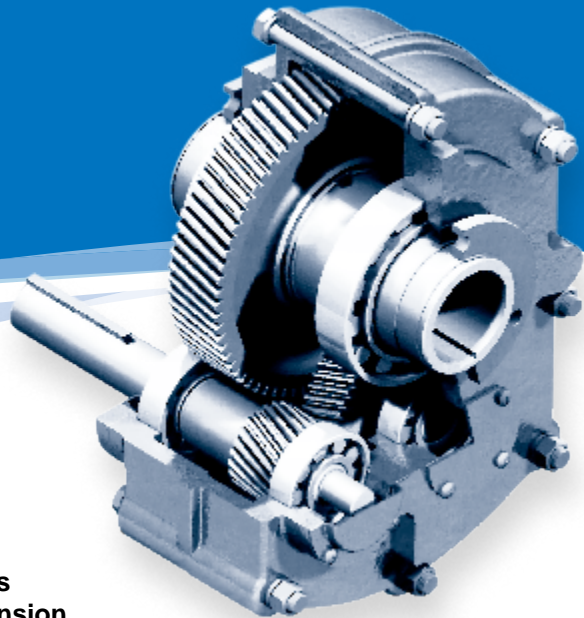

Features

Challenge TXT range of Shaft Mounted Speed Reducers are inch in design for America and other imperial dimension countries.

Challenge TXT gear units are manufactured in eight gear case sizes, from size 2 to size 9, maximum power up to 150hp, nominal gear ratios are 15:1 and 25:1. A wide choice of final driven speeds can be determined by the use of an appropriate input belt drive. The units will normally be oil lubricated, but they are equally suitable for long life synthetic lubricants.

1. Twin Tapered Output Hub

A tapered bore in both sides of the reducer's output hub snugs up against a matching taper on the outer surface of the bushing. Bushing mounting screws pass through the bushing flange into a mounting collar on the hub. As the screws are tightened, the bushing moves inward, gripping the driven machine's input shaft tightly and evenly around every point on its circumference. It is easy-on, easy-off. All of the output bushing bores accord to ANSI standards. Also available are ISO standard straight bore output hubs.

2. Precision High Quality Gearing

Computer designed helical gears, strong alloy materials for high load capacity, case carburized for long life, ground profile, crown tooth profile, in conformance with ISO 1328-1997. 98% efficiency per stage, smooth quiet operation with several teeth in mesh.

3. Power Ratings

All TXT SMSR's have power ratings to ISO standards.

4. Maximum Capacity Housing Design

Close grain cast iron construction. Excellent vibration dampening and shock resistance features. Precision bored and dowelled to ensure accurate in-line assembly.

5. Strong Alloy Steel Shafts

Strong alloy steel, hardened, ground on journals, gear seatings and extensions, for maximum load and maximum torsional loads. Generous size shaft keys for shock loading.

6. Using an adapter for mounting the torque arm increases the strength of the gear case. The torque arm is easy-on and easy-off for reliability and controls the position of the standard torque arm mounting within recommended limits.

7. BackStops

As an optional part, anti-run back devices are available.

8. Bearing and Oilseals

Bearings are all tapered roller (except TXT2), having long life service time. Oilseals are double lipped garter spring type, ensuring effective oil sealing.

9. Torque Arm Assembly

For easy adjustment of the belt.

Shaft Mounted Speed Reducer

TXT Speed Reducer Selection Procedure

The selection tables for Challenge TXT Shaft Mounted Reducers are for electric motor selections up to 150hp with output speeds up to 400rpm using AGMA recommended application class numbers. For extreme shock or high energy loads which must be absorbed, as when stalling; for power source other than an electric motor; or for extreme ambient temperatures, or oversized equipment, consult Challenge.

Step 1: Determine Class of Service - See table 1, page 381 to 383, to determine the Load Classification for applications under normal conditions. Find the type application and duty cycle that most closely matches your specific application.

Class I Steady loads not exceeding motor hp rating and light shock loads operating up to 10 hours a day. Moderate shock loads are allowable if the operation is intermittent.

For Class I applications, the maximum value of starting and momentary peak loads should not exceed 2 x motor hp rating. If it exceeds this amount it should be divided by 2 and the result used in the selection table instead of the motor hp rating.

Class II Steady load not exceeding motor hp rating for over 10 hours a day. Moderate shock loads are allowable for up to 10 hours a day.

For Class II applications, the maximum value of starting and momentary peak loads should not exceed 2.8 x motor hp rating. If it exceeds this amount it should be divided by 2.8 and the result used in the selection table instead of the motor hp rating.

Class III Moderate shock loads for over 10 hours a day. Heavy shock loads are allowable up to 10 hours a day.

For Class III applications, the maximum value of starting and momentary peak loads should not exceed 4 x motor hp rating. If it exceeds this amount it should be divided by 4 and the result used in the selection table instead of the motor hp rating.

Step 2: Determine Reducer Size - See the selection tables, pages 384 through 386. From selection tables class I, II or III read the reducer size for the application horsepower and output speed. Note: For applications where fan cooling is unacceptable, use the selection tables with an increased class number. Where more than one reducer selection is listed, the most economical ratio is generally listed first. See table 11, page 400 for maximum input and output speeds.

Step 3: Compare Hollow Shaft Bore of the TXT425 with the size of the driven shaft. All Challenge taper bushed Shaft Mount Reducers require bushings. Refer to reducer page 396 table 7 for available bushings. If the driven shaft is larger than the bore of the selected reducer, the shaft must

be machined to the proper size, or select a larger reducer. Check driven shaft and key for strength.

Step 4: Check Dimensions - See table 5, page 395 for reducer dimensions, table 11, page 400 for reducer weights and actual ratio. See page 397 for reducer mounting positions.

Step 5: Select a Belt Drive Arrangement - From the Belt Drives tables, page 387 to 394, select the required sheave ratio for the belt drive. Be careful to select the belt drive so that the sheave mounted on the reducer shaft is not smaller than the minimum sheave diameter with table 14 page 400. Note: Mount the sheave as close as possible to the reducer to minimize the effect of the overhung load on the reducer.

Note: For different bore diameters, bushings must be ordered separately, Backstops also need to be ordered separately. Torque arm and adapter are standard parts for the reducer. Each reducer unit is dispatched with them.

Selection Example

A 10 hp 1750rpm motor is used to drive an uniformly loaded belt conveyor moving sand, operating 16 hours a day. Head pulley shaft diameter is 2.7/16" and rotates at 70rpm. The driven conveyor cannot be allowed to move backwards.

Step 1: Determine Class of Service - From page 381 table 1, locate "belt conveyors, uniformly loaded or fed" for over 10 hours per day. This load is classified as a Class II application.

Step 2: Determine Reducer Size - From table 3 - Class II Application, page 385, find the column for 10 hp and read down to 70 rpm. A TXT 425 reducer is the correct selection.

Step 3: Compare Hollow Shaft Bore of TXT 425 with the application driven shaft diameter, page 396, 2.7/16" is the maximum bore available for this size reducer, so it will work on this application. Be sure to check the driven shaft and key strength.

Step 4: Check Dimensions and Weights - See page 395, for reducer dimensions, table 11, page 400 for reducer weights and actual ratio, etc. See page 397 for information on mounting positions.

Step 5: Select a Belt Drive Arrangement - From the Belt Drive table page 389, read down for 70rpm, find the V-Belt drive ratio of 1.03. Sheave diameter of driver is 6.20", the driven is 6.40", belt size is B, belt number is 3. From table 14, page 400, the TXT 425's minimum sheave diameter is 4.60", so the selection is correct.

Step 6: The reducer cannot be allowed to move backwards, so the backstop assembly must be ordered.

Note: when you need to assembly the backstop on the reducer, please specify the output rotation direction when you order. For example, from the input side, the output hub rotates clockwise.

Shaft Mounted Speed Reducer

Application Classification

Table 1 Application Classification and Class Numbers

Application	Class Numbers		Application	Class Numbers	
	3 to 10 Hrs per Day	Over 10 Hrs per Day		3 to 10 Hrs per Day	Over 10 Hrs per Day
Agitators (Mixers)			Stackers	II	II
Pure Liquids	I	II	Winches	II	II
Liquids and Solids	II	II	Elevators		
Liquids-Variable Density	II	II	Bucket	II	II
Blowers			Centrifugal Discharge	I	II
Centrifugal	I	II	Escalators	I	II
Lobe	II	II	Freight	II	II
Vane	II	II	Gravity Discharge	I	II
Brewing and Distilling			Extruders		
Bottling Machinery	I	II	General	II	II
Brew Kettles-Continuous Duty	II	II	Plastics		
Cookers-Continuous Duty	II	II	Variable Speed Drive	III	III
Mash Tubs-Continuous Duty	II	II	Fixed Speed Drive	III	III
Scale Hopper-Frequent Starts	II	II	Rubber		
Can Filling Machines	I	II	Continous Screw Operation	III	III
Car Dumpers	III	III	Intermittent Screw Operation	III	III
Car Pullers	II	II	Fans		
Clarifiers	I	II	Centrifugal	I	II
Classifiers	II	II	Forced Draft	II	II
Clay Working Machinery			Induced Draft	II	II
Brick Press	III	III	Industrial & Mine	II	II
Briquette Machine	III	III	Feeders		
Pug Mill	II	II	Apron	II	II
Compactors	III+	III+	Belt	II	II
Compressors			Disc	I	II
Centrifugal	I	II	Reciprocating	III	III
Lobe	II	II	Screw	II	II
Reciprocating, Multi-Cylinder	II	III	Food Industry		
Reciprocating, Single-Cylinder	III	III	Cereal Cooker	I	II
Conveyors			Dough Mixer	II	II
(Includes Apron, Assembly, Belt, Bucket, Chain, Flight, Oven and Screw)			Meat Grinder	II	II
Uniformly Loaded or Fed	I	II	Slicers	II	II
Heavy Duty-Not Uniformly Fed	II	II	Generators and Exciters	II	II
Severe Duty-Reciprocating or Shaker	III	III	Hammer Mills	II	II
Cranes	III+	III+	Hoists	III+	III+
Crusher			Laundry Tumblers	II	II
Stone or Ore	III	III	Laundry Washers	II	II
Dredges			Lumber Industry		
Cable Reels	II	II	Bakers		
Conveyors	II	II	Spindle Feed	II	II
Cutter Head Drives	III	III	Main Drive	III	III
Pumps	III	III	Conveyors		
Screen Drives	III	III			

III+ Large service factor needed, consult Challenge for more information on class number.

Shaft Mounted Speed Reducer

Application Classification

Table 1 Application Classification and Class Numbers (continued)

Application	Class Numbers		Application	Class Numbers	
	3 to 10 Hrs per Day	Over 10 Hrs per Day		3 to 10 Hrs per Day	Over 10 Hrs per Day
Burner	II	II	Coilers & Uncoilers	I	II
Main or Heavy Duty	II	II	Edge Trimmers	II	II
Main Log	III	III	Flatteners	II	II
Re-saw, Merry-Go-Round	II	II	Loopers (Accumulators)	I	I
Slab	III	III	Pinch Rolls	II	II
Transfer	II	II	Scrap Choppers	II	II
Chains			Shears	III	III
Floor	II	II	Slitters	II	II
Green	II	III	Mills. Rotary Type		
Cut-Off Saws			Ball & Rod		
Chain	II	III	Spur Ring Gear	III	III
Drag	II	III	Helical Ring Gear	II	II
Debarking Drums	III	III	Direct Connected	III	III
Feeds			Cement Kilns	II	II
Edger	II	II	Dryers & Coolers	II	II
Gang	III	III	Mixers Cement	II	II
Trimmer	II	II	Paper Mills		
Log Deck	III	III	Agitators (Mixers)	II	II
Log Hauls-Incline-Well Type	III	III	Agitators for Pure Liquors	II	II
Log Tuning Devices	III	III	Barking Drums	III	III
Planer Feed	II	II	Barkers-Mechanical	III	III
Planer Tilting Hoists	II	II	Beater	II	II
Rolls-Live-off brg.-Roll Cases	III	III	Breaker Stack	II	II
Sorting Table	II	II	Chipper	III	III
Triple Hoist	II	II	Chip Feeder	II	II
Transfers			Coating Rolls	II	II
Chain	II	III	Conveyors		
Craneway	II	III	Chip, Bark, Chemical	II	II
Tray Drives	II	II	Log (including Slab)	III	III
Veneer Lathe Drives	II	II	Couch Rolls	II	II
Metal Mills			Cutter	III	III
Draw bench Carriage and Main Drive	II	II	Cylinder Molds	II	II
Runout Table			Embossers	II	II
Non-Reversing-Group Drives	II	II	Extruder	II	II
Non-Reversing-Individual Drives	III	III	Fourdrinier Rolls (includes Lump breaker, dandy roll, wire tuning, and return rolls)	II	II
Reversing Drives	III	III	Jordan	II	II
Slab Pushers	II	II	Kiln Drive	II	II
Shears	III	III	Mt. Hope Roll	II	II
Wire Drawing	II	II	Paper Rolls	II	II
Wire Winding Machine	II	II	Platter	II	II
Metal Strip Processing Machinery			Presses-Felt & Suction	II	II
Bridles	II	II			

Every effort has been taken to ensure that the data listed in this catalogue is correct. Challenge accepts no liability for any inaccuracies or damage caused.

Shaft Mounted Speed Reducer

Application Classification

Table 1 Application Classification and Class Numbers (continued)

Application	Class Numbers		Application	Class Numbers	
	3 to 10 Hrs per Day	Over 10 Hrs per Day		3 to 10 Hrs per Day	Over 10 Hrs per Day
Pulper	III	III	Cracker Warmer - 2 roll, 1 corrugated roll	III	III
Pump-Vacuum	II	II	Cracker - 2 corrugated rolls	III	III
Reel (Surface Type)	II	II	Holding, Feed & Blend Mill-2 rolls	II	II
Screens			Refiners-2 rolls	II	II
Chip	II	II	Calenders	II	II
Rotary	II	II	Sand Muller	II	II
Vibrating	III	III	Sewage Disposal Equipment		
Size Press	II	II	Bar Screens	II	II
Thickener (AC Motor)	II	II	Chemical Feeders	II	II
Thickener (DC Motor)	II	II	Dewatering Screens	II	II
Washer (AC Motor)	II	II	Scum Breakers	II	II
Washer (DC Motor)	II	II	Slow or Rapid Mixers	II	II
Wind and Unwind Stand	I	I	Sludge Collectors	II	II
Winders (Surface Type)	II	II	Thickener	II	II
Plastics Industry-Secondary Processing			Vacuum Filters	II	II
Blow Molders	II	II	Screens		
Coating	II	II	Air Washing	I	II
Film	II	II	Rotary-Stone or Gravel	II	II
Pipe	II	II	Traveling Water Intake	I	I
Pre-Plasticizers	II	II	Screw Conveyors		
Rods	II	II	Uniformly Loaded or Fed	I	II
Sheet	II	II	Heavy Duty	II	II
Tubing	II	II	Sugar Industry		
Pullers-Barge Haul	II	II	Beet Slicer	III	III
Pumps			Cane Knives	II	II
Centrifugal	I	II	Crushers	II	II
Proportioning	II	II	Mills (low speed end)	III	III
Reciprocating			Textile Industry		
Single Acting, 3 or more cylinders	II	II	Batches	II	II
Double Acting, 2 or more cylinders	II	II	Calenders	II	II
Rotary			Cards	II	II
Gear Type	I	II	Dry Cans	II	II
Lobe	I	II	Dyeing Machinery	II	II
Vane	I	II	Looms	II	II
Rubber and Plastics Industry			Mangles	II	II
Intensive Internal Mixers			Nappers	II	II
Batch Mixers	III	III	Pads	II	II
Continous Mixers	II	II	Stashers	II	II
Mixing Mill			Soapers	II	II
2 smooth rolls	II	II	Spinners	II	II
2 corrugated rolls	III	III	Tenter Frames	II	II
Batch Drop Mill-2 smooth rolls	II	II	Washers	II	II
			Winders	II	II

Every effort has been taken to ensure that the data listed in this catalogue is correct. Challenge accepts no liability for any inaccuracies or damage caused.

Shaft Mounted Speed Reducer

TXT Power Ratings

Table 2 Class I Selection Table for TXT SMSR's

Rating HP	Output rpm	Reducer Selection	Rating HP	Output rpm	Reducer Selection
1/2	4~6	225	15	57~70	425 415
3/4	4~5	325		70~85	415 425
	6~10	225		86~93	415
1	4~5	425		94~140	315
	6~7	325	9~12	926	
	8~15	225	13~18	825	
1-1/2	4	525	19~26	725 715	
	5~7	425	27~45	625 615	
	8~12	325	46~70	525 515	
	13~23	225	71~78	515 525	
2	4~6	525	79~85	415 425	
	7~10	425	86~115	415	
	11~17	325	116~140	415*	
	18~32	225 215	11~15	926	
3	4~5	625	16~23	825	
	6~10	525	24~33	725 715	
	11~15	425	34~59	625 615	
	16~26	325	60~70	525* 515*	
	27~51	225 215	71~80	515* 525*	
5	5~6	725	81~101	515*	
	7~9	625	102~140	415*	
	10~17	525	14~19	926	
	18~26	425 415	20~28	825 815	
	27~46	325 315	29~41	725 715	
	47~70	225 215	42~70	625 615	
7-1/2	71~85	215 225	71~75	615 625	
	86~92	215	76~125	515*	
	4~6	825	19~25	926 915	
	7~9	725	26~38	825 815	
	10~15	625	39~57	725 715	
	16~26	525	58~70	625 615	
	27~40	425 415	71~81	615* 625*	
	41~70	325 315	812~114	615*	
	71~74	315 325	115~125	515*	
	75~85	215 225	23~32	926 915	
86~140	215	33~49	825 815		
10	5	926	50~70	725 715	
	6~8	825	71~74	715 725	
	9~12	725	75~125	615*	
	13~20	625	28~39	926 915	
	21~36	525 515	40~60	825 815	
	37~56	425 415	61~70	725* 715*	
	57~70	325 315	71~120	715*	
	71~85	315 325	35~50	926 915	
	86~103	315	51~70	825 815	
	104~140	215	71~78	815*	
15	7~8	926	79~120	715*	
	9~13	825	47~69	926* 915*	
	14~19	725	70~120	815*	
	20~32	625 615	60~70	915* 926*	
	33~56	525 515	71~90	915*	
			91~123	815*	
		150	81~120	915	

* Fan cooling required.

Every effort has been taken to ensure that the data listed in this catalogue is correct. Challenge accepts no liability for any inaccuracies or damage caused.

Shaft Mounted Speed Reducer

TXT Power Ratings

Table 3 Class II Selection Table for TXT SMSR's

Rating HP	Output rpm	Reducer Selection	Rating HP	Output rpm	Reducer Selection	
1/3	4~6	225	15	10~12	926	
1/2	4~5	325		13~19	825	
	6~9	225		20~27	725	
3/4	4~5	425		28~47	625 615	
	6~8	325		48~70	525 515	
	9~16	225		71~82	515 525	
1	5~7	425		83~140	415	
	8~11	325		20	13~17	926
	12~22	225			18~26	825
1-1/2	5~6	525			27~38	725 715
	7~11	425	39~68		625 615	
	12~18	325	69~80		515 525	
2	19~34	225 215	81~89		515	
	4~5	625	90~117		515*	
	6~9	525	118~125		415*	
	10~14	425	25		16~22	926
	15~24	325 315			23~33	825 815
25~47	225 215	34~49		725 715		
3	4~5	725		50~80	615 625	
	6~8	625		81~94	615	
	9~14	525		95~125	515*	
	15~22	425 415		30	20~27	926 915
	23~38	325 315			28~41	825 815
39~70	225 215	42~60			725 715	
71~75	215 225	61~76			625 615	
5	4~6	825	77~89		615	
	7~8	725	90~125	615*		
	9~14	625	40	26~36	926 915	
	15~24	525		37~56	825 815	
	25~37	425 415		57~75	725 715	
	38~69	325 315		76~88	715	
	70~85	215 225		89~120	615*	
86~136	215	50		33~46	926 915	
7-1/2	5			926	47~70	825 815
	6~9		825	71~72	815 825	
	10~13		725	73~120	715*	
	14~21		625	60	40~56	926 915
	22~38	525 515	57~70		825 815	
	39~59	425 415	71~75		815 825	
	60~70	325 315	76~89		815	
	71~85	325 315	90~120		715*	
	86~110	315	75	50~73	926 915	
	111~140	215		74~75	815 825	
10	6~7	926		76~120	815*	
	8~12	825		100	68~75	915* 926*
	13~18	725			76~103	915*
	19~29	625 615	104~120		815*	
	30~52	525 515	125	86~120	915*	
	53~70	425 415				
	71~84	415 425				
	85~140	315				

* Fan cooling required.

Shaft Mounted Speed Reducer

TXT Power Ratings

Table 4 Class III Selection Table for TXT SMSR's

Rating HP	Output rpm	Reducer Selection	Rating HP	Output rpm	Reducer Selection	
1/4	4~6	225	7-1/2	57~70	425 415	
1/3	5~9	225		71~85	415 425	
1/2	4~5	425		86~93	415	
	6~7	325		94~140	315	
3/4	8~15	225	10	9~12	926	
	4	525		13~18	825	
	5~7	425		19~26	725 715	
	8~12	325		27~45	625 615	
13~23	225	46~70		525 515		
1	4~6	525		71~78	515 525	
	7~10	425	79~141	415		
	11~17	325	15	14~19	926	
	18~32	225		20~28	825 815	
1-1/2	4~5	625		29~41	725 715	
	6~10	525		42~70	625 615	
	11~15	425		71~75	615 625	
	16~26	325		76~125	515	
2	27~51	225 215	20	19~25	926 915	
	5~7	625		26~38	825 815	
	8~13	525		39~57	725 715	
	14~21	425		58~70	625 615	
	22~36	325 315		71~114	615	
3	37~71	225 215	25	115~125	515*	
	4~5	825		23~32	926 915	
	6~7	725		33~49	825 815	
	8~12	625		50~70	725 715	
	13~20	525		71~74	715 725	
	21~32	425 415		75~104	615	
	33~57	325 315	30	105~125	615*	
	58~70	225 215		28~39	926 915	
	71~85	215 225		40~60	825 815	
	86~113	215		61~70	725 715	
5	5	926	40	71~98	715	
	6~8	825		99~125	615	
	9~12	725		50	38~53	926 915
	13~20	625			54~70	825 815
	21~36	525 515			71~84	815
	37~56	425 415			85~89	715
	57~70	325 315	60	90~120	715*	
	71~85	315 325		47~69	926 915	
	86~103	315		70~75	815 825	
	104~140	215		76~110	815	
7-1/2	7~8	926	75	111~120	715*	
	9~13	825		57~75	926 915	
	14~19	725		76~85	915	
	20~32	625 615		86~115	815	
	33~56	525 515		73~75	915* 926*	
			76~120	915*		

* Fan cooling required.

Every effort has been taken to ensure that the data listed in this catalogue is correct. Challenge accepts no liability for any inaccuracies or damage caused.

Shaft Mounted Speed Reducer

Belt Drives for 1750 rpm motors

TXT 215 Driven by 1750 rpm Motors									
Out-put rpm	V-belt Drive Ratio	Sheave Diameters		Qty. & Belt Size	Out-put rpm	V-belt Drive Ratio	Sheave Diameters		Qty. & Belt Size
		Motor	Reducer				Motor	Reducer	
17	7.17	2.65	19.00	2-3V	76	1.63	3.80	6.20	4-A
20	6.33	3.00	19.00	2-3V	77	1.62	6.80	11.00	2-B
21	6.00	3.00	18.00	3-A	78	1.60	5.00	8.00	3-3V
22	5.67	3.35	19.00	2-3V	79	1.57	6.00	9.40	2-B
22	5.63	3.20	18.00	2-A	81	1.53	4.50	6.90	3-3V
24	5.29	3.40	18.00	2-A	81	1.53	3.80	5.80	4-A
24	5.28	2.65	14.00	3-3V	83	1.50	3.60	5.40	4-A
25	5.00	3.60	18.00	2-A	84	1.49	3.35	5.00	4-3V
27	4.69	3.20	15.00	2-A	85	1.47	3.40	5.00	4-A
27	4.67	3.00	14.00	2-3V	85	1.47	6.40	9.40	2-B
29	4.29	4.20	18.00	2-A	85	1.46	4.12	6.00	3-3V
30	4.22	4.50	19.00	2-3V	87	1.43	6.00	8.60	2-B
30	4.09	4.40	18.00	2-A	88	1.42	3.35	4.75	4-3V
31	4.00	2.65	10.60	3-3V	88	1.41	3.40	4.80	4-A
31	4.00	3.00	12.00	3-A	90	1.39	4.60	6.40	3-A
33	3.75	3.20	12.00	3-A	90	1.39	6.20	8.60	2-B
35	3.60	5.00	18.00	2-A	91	1.37	4.75	6.50	3-3V
35	3.58	5.30	19.00	2-3V	93	1.34	3.35	4.50	4-3V
35	3.53	3.00	10.60	3-3V	93	1.34	6.40	8.60	2-B
35	3.53	3.00	10.60	3-A	94	1.33	4.50	6.00	3-3V
38	3.31	3.20	10.60	3-A	94	1.33	3.60	4.80	4-A
38	3.26	4.60	15.00	2-A	94	1.33	8.00	10.60	2-3V
39	3.21	4.80	15.40	2-B	94	1.32	3.80	5.00	4-A
39	3.16	3.35	10.60	3-3V	97	1.29	4.12	5.30	3-3V
40	3.12	3.40	10.60	3-A	97	1.29	4.80	6.20	3-A
40	3.11	4.50	14.00	2-3V	97	1.28	3.60	4.60	4-A
41	3.02	2.65	8.00	3-3V	100	1.25	4.80	6.00	3-A
42	3.00	4.00	12.00	2-A	101	1.23	6.50	8.00	2-3V
44	2.86	2.80	8.00	3-3V	101	1.23	6.00	7.40	2-B
44	2.86	4.20	12.00	2-A	102	1.22	4.60	5.60	3-A
45	2.75	6.90	19.00	2-3V	103	1.21	4.12	5.00	3-3V
46	2.73	3.00	8.20	3-A	103	1.21	3.80	4.60	3-A
46	2.73	4.40	12.00	2-A	104	1.20	5.00	6.00	3-3V
47	2.67	3.00	8.00	3-3V	105	1.19	5.20	6.20	3-B
48	2.58	4.80	12.40	2-B	105	1.19	5.40	6.40	3-B
49	2.54	3.15	8.00	4-3V	106	1.18	4.50	5.30	4-3V
50	2.48	5.00	12.40	2-B	107	1.17	4.80	5.60	3-B
52	2.42	6.20	15.00	2-A	107	1.16	5.60	6.50	3-3V
52	2.39	3.35	8.00	3-3V	107	1.16	7.40	8.60	2-B
52	2.38	5.20	12.40	2-B	109	1.14	4.20	4.80	4-A
53	2.33	3.00	7.00	4-A	111	1.12	5.00	5.60	3-3V
54	2.30	3.00	6.90	4-3V	111	1.12	5.00	5.60	3-B
54	2.29	4.80	11.00	2-B	113	1.10	4.20	4.60	4-A
57	2.20	5.00	11.00	2-B	115	1.08	6.00	6.50	3-3V
57	2.19	3.65	8.00	3-3V	115	1.08	4.80	5.20	3-B
58	2.16	3.80	8.20	3-A	118	1.06	5.00	5.30	3-3V
59	2.12	5.00	10.60	2-3V	118	1.06	6.20	6.60	3-B
59	2.12	5.20	11.00	2-B	120	1.04	5.00	5.20	3-B
61	2.04	5.40	11.00	2-B	121	1.03	6.60	6.80	3-B
61	2.03	6.90	14.00	2-3V	125	1.00	4.12	4.12	4-3V
64	1.96	4.80	9.40	2-B	125	1.00	8.60	8.60	2-B
66	1.90	5.80	11.00	2-B	128	0.97	6.00	5.80	3-A
66	1.89	3.65	6.90	3-3V	130	0.96	5.00	4.80	3-B
66	1.88	5.00	9.40	2-B	131	0.95	5.60	5.30	3-3V
67	1.87	3.00	5.60	4-3V	131	0.95	3.80	3.60	5-A
67	1.87	3.00	5.60	4-A	134	0.93	6.00	5.60	3-3V
68	1.83	5.80	10.60	2-A	134	0.93	5.80	5.40	3-B
70	1.79	3.35	6.00	3-3V	134	0.93	5.40	5.00	3-B
70	1.79	4.80	8.60	2-B	135	0.92	6.50	6.00	3-3V
71	1.75	8.00	14.00	2-3V	135	0.92	5.20	4.80	3-B
72	1.74	5.40	9.40	2-B	135	0.92	4.50	4.12	4-3V
72	1.72	5.00	8.60	2-B	137	0.91	9.40	8.60	2-B
74	1.68	5.60	9.40	2-B	137	0.91	4.40	4.00	4-A
75	1.67	3.35	5.60	3-3V	138	0.90	5.30	4.75	3-3V
76	1.63	6.50	10.60	2-3V	140	0.89	5.60	5.00	3-B

TXT 225 Driven by 1750 rpm Motors									
Out-put rpm	V-belt Drive Ratio	Sheave Diameters		Qty. & Belt Size	Out-put rpm	V-belt Drive Ratio	Sheave Diameters		Qty. & Belt Size
		Motor	Reducer				Motor	Reducer	
10	7.17	2.65	19.00	2-3V	49	1.54	5.60	8.60	2-B
12	6.33	3.00	19.00	2-3V	49	1.53	3.65	5.60	3-3V
12	6.00	3.00	18.00	2-A	50	1.51	5.30	8.00	2-3V
14	5.29	3.40	18.00	2-A	50	1.49	3.35	5.00	3-3V
14	5.28	2.65	14.00	2-3V	51	1.48	5.00	7.40	2-B
15	5.00	2.80	14.00	2-3V	51	1.46	5.60	8.20	2-A
15	5.00	3.00	15.00	2-A	52	1.45	3.65	5.30	3-3V
16	4.69	3.20	15.00	2-A	53	1.42	5.20	7.40	2-B
16	4.67	3.00	14.00	2-3V	53	1.42	4.80	6.80	2-B
17	4.44	3.15	14.00	2-3V	53	1.42	3.35	4.75	3-3V
17	4.41	3.40	15.00	2-A	54	1.38	5.00	6.90	2-3V
18	4.18	3.35	14.00	2-3V	54	1.38	4.80	6.60	2-B
18	4.17	3.60	15.00	2-A	56	1.33	6.00	8.00	2-3V
19	3.95	3.80	15.00	2-A	56	1.33	4.80	6.40	2-B
20	3.84	3.65	14.00	2-3V	57	1.32	5.00	6.60	2-B
20	3.75	3.20	12.00	2-A	58	1.30	5.00	6.50	2-3V
22	3.37	3.15	10.60	2-3V	58	1.29	4.80	6.20	2-B
22	3.33	3.60	12.00	2-A	58	1.29	4.12	5.30	3-3V
23	3.31	3.20	10.60	2-A	59	1.27	5.20	6.60	2-B
24	3.16	3.35	10.60	2-3V	59	1.26	4.75	6.00	3-3V
24	3.12	3.40	10.60	2-A	60	1.25	4.80	6.00	2-B
25	3.02	2.65	8.00	3-3V	61	1.23	5.60	6.90	2-3V
25	2.94	3.60	10.60	2-A	61	1.23	5.30	6.50	2-3V
26	2.90	3.65	10.60	2-3V	61	1.23	5.20	6.40	2-B
26	2.86	4.20	12.00	2-A	62	1.20	5.00	6.00	2-3V
26	2.86	2.80	8.00	3-3V	62	1.21	4.80	5.80	2-B
27	2.75	6.90	19.00	2-3V	64	1.17	4.80	5.60	2-B
27	2.73	4.40	12.00	2-A	65	1.16	5.60	6.50	2-3V
28	2.65	4.00	10.60	2-A	65	1.15	6.00	6.90	2-3V
29	2.61	4.60	12.00	2-A	65	1.15	5.20	6.00	2-B
29	2.60	2.65	6.90	3-3V	66	1.13	5.30	6.00	2-3V
29	2.54	3.15	8.00	3-3V	66	1.13	4.80	5.40	2-B
30	2.52	4.20	10.60	2-A	67	1.12	5.00	5.60	2-3V
31	2.45	2.65	6.50	3-3V	67	1.12	5.00	5.60	2-B
31	2.41	4.40	10.60	2-A	68	1.10	5.80	6.40	2-B
31	2.39	3.35	8.00	3-3V	69	1.09	4.12	4.50	3-3V
33	2.26	2.65	6.00	3-3V	69	1.08	6.00	6.50	2-3V
33	2.25	4.00	9.00	2-A	69	1.08	4.80	5.20	2-B
34	2.21	4.80	10.60	2-A	70	1.07	5.60	6.00	2-B
34	2.19	3.65	8.00	2-3V	71	1.06	5.00	5.30	2-3V
35	2.14	4.20	9.00	2-A	71	1.06	5.30	5.60	2-3V
35	2.11	2.65	5.60	3-3V	71	1.06	3.60	3.80	3-A
36	2.06	3.15	6.50	3-3V	72	1.04	5.00	5.20	2-B
37	2.05	4.00	8.20	2-A	75	1.00	6.20	6.20	2-B
37	2.04	4.60	9.40	2-B	75	1.00	4.50	4.50	3-3V
37	2.00	2.65	5.30	3-3V	77	0.97	6.40	6.20	2-B
38	1.95	4.20	8.20	2-A	80	0.94	6.90	6.50	2-3V
39	1.94	4.12	8.00	2-3V	80	0.94	6.60	6.20	2-B
39	1.93	3.00	5.80	3-A	80	0.94	6.40	6.00	2-B
40	1.89	3.65	6.90	2-3V	81	0.92	7.40	6.80	2-B
40	1.87	3.00	5.60	3-3V	81	0.93	6.00	5.60	3-3V
40	1.86	4.40	8.20	2-A	81	0.92	4.50	4.12	3-3V
42	1.80	5.00	9.00	2-A	81	0.92	3.65	3.35	4-3V
42	1.78	3.65	6.50	2-3V	82	0.91	6.60	6.00	2-B
42	1.79	2.65	4.75	3-3V	83	0.90	5.00	4.50	3-3V
42	1.78	4.60	8.20	2-A	84	0.89	7.40	6.60	2-B
44	1.71	4.80	8.20	2-A	84	0.89	4.12	3.65	4-3V
45	1.67	4.12	6.90	2-3V	84	0.89	3.80	3.40	4-A
45	1.67	4.20	7.00	2-A	85	0.88	6.60	5.80	2-B
46	1.64	3.65	6.00	2-3V	85	0.88	6.00	5.30	3-3V
47	1.61	4.60	7.40	2-B					
47	1.61	2.80	4.50	3-3V					
47	1.59	5.40	8.60	2-B					
47	1.58	3.35	5.30	3-3V					
49	1.54	4.80	7.40	2-B					

Every effort has been taken to ensure that the data listed in this catalogue is correct. Challenge accepts no liability for any inaccuracies or damage caused.

All dimensions in inches unless otherwise stated.

Shaft Mounted Speed Reducer

Belt Drives for 1750 rpm motors

TXT 315 Driven by 1750 rpm Motors									
Out-put rpm	V-belt Drive Ratio	Sheave Diameters		Qty. & Belt Size	Out-put rpm	V-belt Drive Ratio	Sheave Diameters		Qty. & Belt Size
		Motor	Reducer				Motor	Reducer	
12	9.43	2.65	25.00	3-3V	72	1.64	3.65	6.00	4-3V
16	7.17	2.65	19.00	3-3V	73	1.62	5.80	9.40	3-B
19	6.33	3.00	19.00	2-3V	74	1.60	5.00	8.00	3-3V
20	6.03	3.15	19.00	3-3V	75	1.57	6.00	9.40	3-B
20	6.00	3.00	18.00	3-A	76	1.54	4.80	7.40	3-B
21	5.67	3.35	19.00	3-3V	77	1.53	4.50	6.90	4-3V
21	5.63	3.20	18.00	3-A	77	1.52	4.20	6.40	4-A
22	5.29	3.40	18.00	3-A	79	1.49	7.40	11.00	2-B
22	5.28	2.65	14.00	3-3V	81	1.45	4.40	6.40	4-A
24	5.00	2.80	14.00	3-3V	82	1.44	4.50	6.50	4-3V
24	5.00	3.00	15.00	3-A	83	1.42	4.80	6.80	3-B
25	4.69	3.20	15.00	3-A	85	1.38	5.00	6.90	3-3V
25	4.67	3.00	14.00	3-3V	85	1.38	4.20	5.80	4-A
27	4.29	4.20	18.00	2-A	87	1.36	14.00	19.00	2-3V
28	4.22	4.50	19.00	2-3V	87	1.35	4.60	6.20	4-A
28	4.17	3.60	15.00	3-A	88	1.33	8.00	10.60	2-3V
29	4.00	2.65	10.60	3-3V	89	1.32	5.00	6.60	3-B
29	4.00	3.00	12.00	3-A	91	1.29	4.12	5.30	4-3V
31	3.79	2.80	10.60	3-3V	91	1.29	4.80	6.20	3-B
31	3.75	3.20	12.00	3-A	92	1.28	5.00	6.40	3-B
32	3.68	5.00	18.40	2-B	94	1.25	4.80	6.00	3-B
35	3.41	4.40	15.00	3-A	95	1.24	4.50	5.60	4-3V
35	3.40	4.12	14.00	3-3V	96	1.23	5.30	6.50	3-3V
36	3.31	3.20	10.60	4-A	96	1.23	5.20	6.40	3-B
37	3.16	3.35	10.60	3-3V	98	1.20	5.00	6.00	3-3V
37	3.16	3.80	12.00	3-A	98	1.20	5.00	6.00	3-B
38	3.11	4.50	14.00	3-3V	99	1.19	5.20	6.20	3-B
38	3.08	5.00	15.40	2-B	101	1.16	5.60	6.50	3-3V
40	2.94	3.60	10.60	3-A	101	1.16	7.40	8.60	2-B
41	2.90	3.65	10.60	3-3V	103	1.14	4.20	4.80	4-A
41	2.85	5.40	15.40	2-B	104	1.13	5.30	6.00	3-3V
42	2.80	5.00	14.00	2-3V	104	1.13	4.60	5.20	4-A
42	2.79	3.80	10.60	3-A	104	1.13	4.80	5.40	3-B
44	2.67	3.00	8.00	4-3V	105	1.12	5.00	5.60	3-3V
44	2.65	4.00	10.60	3-A	107	1.10	4.20	4.60	4-A
45	2.61	4.60	12.00	3-A	108	1.09	4.12	4.50	4-3V
46	2.57	4.12	10.60	3-3V	108	1.09	8.60	9.40	2-B
47	2.50	5.60	14.00	2-3V	109	1.08	4.80	5.20	3-B
47	2.48	5.00	12.40	2-B	111	1.06	5.00	5.30	3-3V
50	2.37	3.80	9.00	3-A	111	1.06	6.40	6.80	3-B
51	2.33	6.00	14.00	2-3V	113	1.04	5.00	5.20	3-B
52	2.28	3.60	8.20	4-A	118	1.00	4.12	4.12	4-3V
53	2.23	4.75	10.60	3-3V	118	1.00	8.60	8.60	2-B
54	2.19	3.20	7.00	5-A	121	0.97	6.40	6.20	3-A
54	2.17	3.00	6.50	5-3V	123	0.96	5.20	5.00	3-B
56	2.12	5.20	11.00	3-B	124	0.95	5.60	5.30	3-3V
57	2.06	3.35	6.90	4-3V	124	0.95	3.80	3.60	5-A
57	2.05	4.00	8.20	4-A	127	0.93	6.00	5.60	3-3V
59	2.00	5.30	10.60	3-3V	127	0.93	5.80	5.40	3-B
59	2.00	6.20	12.40	2-B	128	0.92	4.80	4.40	4-A
61	1.94	6.40	12.40	2-B	128	0.92	4.50	4.12	4-3V
62	1.90	3.15	6.00	5-3V	129	0.91	9.40	8.60	2-B
63	1.88	6.60	12.40	2-B	131	0.90	6.20	5.60	3-A
63	1.87	3.00	5.60	5-3V	131	0.90	5.30	4.75	3-3V
65	1.82	6.80	12.40	2-B	131	0.90	5.80	5.20	3-B
65	1.80	5.00	9.00	3-A	134	0.88	6.00	5.30	3-3V
66	1.79	3.35	6.00	4-3V	134	0.88	5.20	4.60	3-B
66	1.78	4.50	8.00	3-3V	134	0.88	4.80	4.20	4-A
66	1.77	6.20	11.00	2-B	135	0.87	4.75	4.12	4-3V
68	1.72	6.40	11.00	2-B	137	0.86	5.80	5.00	3-B
69	1.71	4.80	8.20	3-A	137	0.86	6.50	5.60	3-3V
70	1.68	3.15	5.30	5-3V	137	0.86	8.60	7.40	2-B
70	1.67	4.12	6.90	3-3V	138	0.85	5.40	4.60	3-B
70	1.67	6.60	11.00	2-B	138	0.85	5.60	4.75	3-3V
70	1.68	3.80	6.40	4-A	140	0.84	6.40	5.40	3-A

TXT 325 Driven by 1750 rpm Motors									
Out-put rpm	V-belt Drive Ratio	Sheave Diameters		Qty. & Belt Size	Out-put rpm	V-belt Drive Ratio	Sheave Diameters		Qty. & Belt Size
		Motor	Reducer				Motor	Reducer	
10	7.17	2.65	19.00	2-3V	48	1.48	5.00	7.40	2-B
11	6.33	3.00	19.00	2-3V	48	1.46	4.12	6.00	3-3V
12	6.03	3.15	19.00	2-3V	49	1.43	5.60	8.00	2-3V
12	6.00	3.00	18.00	3-A	49	1.43	6.00	8.60	2-B
13	5.63	3.20	18.00	2-A	50	1.42	3.35	4.75	3-3V
13	5.28	2.65	14.00	3-3V	50	1.42	4.80	6.80	2-B
14	5.00	2.80	14.00	3-3V	51	1.39	3.60	5.00	3-A
14	5.00	3.60	18.00	2-A	51	1.38	5.00	6.90	2-3V
15	4.69	3.20	15.00	2-A	51	1.38	4.80	6.60	2-B
15	4.67	3.00	14.00	2-3V	52	1.37	3.65	5.00	3-3V
16	4.44	3.15	14.00	2-3V	53	1.34	3.35	4.50	3-3V
16	4.41	3.40	15.00	2-A	53	1.33	4.80	6.40	2-B
17	4.18	3.35	14.00	2-3V	54	1.30	5.00	6.50	2-3V
17	4.17	3.60	15.00	2-A	54	1.32	5.00	6.60	2-B
18	3.95	3.80	15.00	2-A	56	1.27	5.20	6.60	2-B
18	3.84	3.65	14.00	2-3V	56	1.26	4.75	6.00	3-3V
19	3.80	5.00	19.00	2-3V	57	1.25	4.80	6.00	2-B
19	3.75	3.20	12.00	3-A	57	1.23	5.60	6.90	2-3V
20	3.53	3.00	10.60	3-3V	57	1.23	5.30	6.50	2-3V
20	3.53	3.00	10.60	3-A	57	1.23	5.20	6.40	2-B
21	3.40	4.12	14.00	2-3V	58	1.21	4.80	5.80	2-B
21	3.31	3.20	10.60	3-A	59	1.20	5.00	6.00	2-3V
22	3.26	4.60	15.00	2-A	59	1.19	5.40	6.40	2-B
22	3.16	3.35	10.60	3-3V	60	1.18	4.50	5.30	3-3V
23	3.12	3.40	10.60	3-A	60	1.17	4.80	5.60	2-B
23	3.02	2.65	8.00	3-3V	61	1.16	5.60	6.50	2-3V
25	2.86	2.80	8.00	3-3V	61	1.15	6.00	6.90	2-3V
25	2.86	4.20	12.00	2-A	61	1.15	5.40	6.20	2-B
26	2.73	4.40	12.00	2-A	63	1.13	4.80	5.40	2-B
26	2.67	3.00	8.00	3-3V	63	1.12	5.00	5.60	2-3V
27	2.65	4.00	10.60	2-A	63	1.12	5.20	5.80	2-B
27	2.60	2.65	6.90	3-3V	64	1.11	4.50	5.00	3-3V
29	2.45	2.65	6.50	3-3V	65	1.08	6.00	6.50	2-3V
29	2.41	4.40	10.60	2-A	65	1.08	4.80	5.20	2-B
30	2.39	4.60	11.00	2-B	65	1.08	5.00	5.40	2-B
30	2.32	2.80	6.50	3-3V	66	1.07	5.60	6.00	2-3V
31	2.26	2.65	6.00	3-3V	68	1.04	5.00	5.20	2-B
31	2.25	4.00	9.00	2-A	69	1.03	6.00	6.20	2-B
32	2.21	4.80	10.60	2-A	71	1.00	5.00	5.00	2-3V
32	2.19	3.65	8.00	2-3V	71	1.00	5.00	5.00	2-B
33	2.12	5.00	10.60	2-3V	74	0.96	5.60	5.40	2-B
33	2.12	5.20	11.00	2-B	74	0.95	3.15	3.00	4-3V
34	2.07	5.80	12.00	2-A	74	0.96	5.00	4.80	2-B
34	2.06	3.35	6.90	3-3V	74	0.95	3.80	3.60	3-A
35	2.04	5.40	11.00	2-B	75	0.94	5.30	5.00	2-3V
35	2.00	3.00	6.00	4-3V	76	0.93	6.00	5.60	2-3V
36	1.96	4.80	9.40	2-B	76	0.93	5.60	5.20	2-B
36	1.94	3.35	6.50	3-3V	79	0.90	6.20	5.60	2-B
37	1.90	5.80	11.00	2-B	79	0.90	5.30	4.75	2-3V
37	1.89	3.65	6.90	3-3V	79	0.89	5.60	5.00	2-B
39	1.81	5.20	9.40	2-B	80	0.88	6.00	5.30	2-3V
40	1.79	4.80	8.60	2-B	80	0.88	5.20	4.60	2-B
40	1.79	3.35	6.00	3-3V	81	0.87	6.20	5.40	2-B
40	1.78	3.65	6.50	3-3V	82	0.86	6.50	5.60	2-3V
41	1.72	5.00	8.60	2-B	82	0.86	5.80	5.00	2-B
43	1.65	5.20	8.60	2-B	83	0.85	5.40	4.60	2-B
43	1.64	3.65	6.00	3-3V	85	0.83	6.00	5.00	2-3V
44	1.60	5.00	8.00	2-3V	85	0.83	6.00	5.00	2-B
44	1.59	5.40	8.60	2-B					
45	1.58	3.35	5.30	3-3V					
45	1.57	6.00	9.40	2-B					
46	1.54	4.80	7.40	2-B					
46	1.53	3.65	5.60	3-3V					
47	1.50	6.00	9.00	2-A					
47	1.49	3.35	5.00	3-3V					

All dimensions in inches unless otherwise stated.

Every effort has been taken to ensure that the data listed in this catalogue is correct. Challenge accepts no liability for any inaccuracies or damage caused.

Shaft Mounted Speed Reducer

Belt Drives for 1750 rpm motors

TXT 415 Driven by 1750 rpm Motors									
Out-put rpm	V-belt Drive Ratio	Sheave Diameters		Qty. & Belt Size	Out-put rpm	V-belt Drive Ratio	Sheave Diameters		Qty. & Belt Size
		Motor	Reducer				Motor	Reducer	
12	9.43	2.65	25.00	3-3V	76	1.53	4.50	6.90	5-3V
13	8.93	2.80	25.00	3-3V	77	1.50	6.00	9.00	4-A
16	7.46	3.35	25.00	3-3V	79	1.47	6.40	9.40	3-B
16	7.17	2.65	19.00	3-3V	80	1.45	4.75	6.90	5-3V
18	6.33	3.00	19.00	3-3V	81	1.43	5.60	8.00	4-3V
19	6.03	3.15	19.00	3-3V	81	1.43	6.00	8.60	3-B
19	6.00	3.00	18.00	3-A	84	1.38	5.00	6.90	4-3V
21	5.63	3.20	18.00	4-A	84	1.38	4.80	6.60	4-B
21	5.56	4.50	25.00	3-3V	86	1.34	6.40	8.60	3-B
23	5.00	3.00	15.00	4-A	87	1.33	4.50	6.00	5-3V
24	4.74	3.80	18.00	3-A	87	1.33	4.80	6.40	4-B
25	4.67	3.00	14.00	4-3V	88	1.32	5.00	6.60	4-B
26	4.44	3.15	14.00	4-3V	89	1.30	7.10	9.25	3-5V
26	4.41	3.40	15.00	4-A	90	1.29	4.80	6.20	4-B
28	4.17	3.60	15.00	4-A	92	1.26	4.75	6.00	5-3V
29	4.00	4.75	19.00	2-3V	92	1.26	6.80	8.60	3-B
29	3.95	3.80	15.00	3-A	92	1.26	5.40	6.80	4-B
31	3.75	4.00	15.00	4-A	93	1.25	4.80	6.00	5-B
32	3.57	4.20	15.00	4-A	94	1.23	5.30	6.50	5-3V
33	3.53	3.00	10.60	5-3V	94	1.23	6.00	7.40	4-B
34	3.41	4.40	15.00	4-A	96	1.21	4.80	5.80	5-B
34	3.37	3.15	10.60	5-3V	96	1.20	5.00	6.00	5-3V
35	3.33	3.60	12.00	4-A	97	1.19	6.20	7.40	4-B
37	3.16	3.80	12.00	4-A	98	1.18	4.75	5.60	6-3V
37	3.11	4.50	14.00	3-3V	98	1.18	5.60	6.60	4-B
38	3.08	5.00	15.40	3-B	99	1.17	5.80	6.80	4-B
39	2.94	3.60	10.60	4-A	101	1.15	8.50	9.75	3-5V
40	2.90	3.65	10.60	4-3V	101	1.14	5.60	6.40	4-B
41	2.85	5.40	15.40	3-B	102	1.13	4.80	5.40	5-B
41	2.80	5.00	14.00	3-3V	103	1.12	5.00	5.60	5-3V
43	2.70	4.60	12.40	4-B	103	1.12	4.75	5.30	6-3V
44	2.64	5.30	14.00	3-3V	104	1.11	5.60	6.20	4-B
44	2.61	4.60	12.00	4-A	105	1.10	5.80	6.40	4-B
46	2.50	5.60	14.00	3-3V	106	1.09	8.50	9.25	3-5V
46	2.50	4.80	12.00	4-A	106	1.09	8.60	9.40	3-B
48	2.41	4.40	10.60	4-A	108	1.07	5.60	6.00	5-3V
49	2.38	5.20	12.40	3-B	108	1.07	5.80	6.20	4-B
49	2.36	4.50	10.60	4-3V	109	1.06	9.00	9.50	3-C
51	2.25	4.00	9.00	5-A	110	1.05	4.75	5.00	6-3V
52	2.23	4.75	10.60	4-3V	111	1.04	5.00	5.20	5-B
52	2.21	5.60	12.40	3-B	116	1.00	5.00	5.00	5-3V
54	2.14	4.20	9.00	4-A	116	1.00	5.80	5.80	4-B
55	2.12	5.00	10.60	3-3V	119	0.97	6.40	6.20	4-B
55	2.12	5.20	11.00	3-B	119	0.97	5.80	5.60	5-B
56	2.07	5.80	12.00	3-A	122	0.95	5.60	5.30	6-3V
57	2.04	5.40	11.00	3-B	123	0.94	9.00	8.50	3-C
57	2.03	6.90	14.00	3-3V	123	0.94	5.30	5.00	6-3V
59	1.96	4.80	9.40	3-B	123	0.94	6.80	6.40	4-B
60	1.94	4.12	8.00	4-3V	124	0.93	5.40	5.00	6-B
61	1.90	5.80	11.00	3-B	126	0.92	6.50	6.00	5-3V
61	1.89	5.60	10.60	3-3V	127	0.91	6.60	6.00	5-B
62	1.88	5.00	9.40	3-B	129	0.90	6.20	5.60	5-B
64	1.81	5.20	9.40	3-B	129	0.90	5.30	4.75	6-3V
65	1.79	10.60	19.00	2-3V	129	0.90	5.80	5.20	5-B
66	1.75	8.00	14.00	2-3V	131	0.88	6.00	5.30	6-3V
66	1.74	5.40	9.40	3-B	131	0.88	5.20	4.60	6-B
67	1.72	6.40	11.00	3-B	133	0.87	6.90	6.00	5-3V
69	1.67	6.60	11.00	3-B	133	0.87	6.00	5.20	5-B
70	1.66	7.10	11.80	3-5V	136	0.85	11.00	9.40	3-B
70	1.65	5.20	8.60	4-B	136	0.85	6.60	5.60	5-B
71	1.62	6.80	11.00	3-B	136	0.85	5.60	4.75	6-3V
72	1.60	5.00	8.00	4-3V	138	0.84	6.40	5.40	5-B
73	1.59	5.40	8.60	4-B	138	0.84	7.40	6.20	4-B
74	1.57	6.00	9.40	3-B	139	0.83	6.00	5.00	6-3V
75	1.54	4.80	7.40	4-B	139	0.83	6.00	5.00	6-B

TXT 425 Driven by 1750 rpm Motors									
Out-put rpm	V-belt Drive Ratio	Sheave Diameters		Qty. & Belt Size	Out-put rpm	V-belt Drive Ratio	Sheave Diameters		Qty. & Belt Size
		Motor	Reducer				Motor	Reducer	
11	6.79	2.80	19.00	2-3V	48	1.49	7.40	11.00	2-B
11	6.79	2.80	19.00	2-3V	49	1.48	5.00	7.40	3-B
11	6.33	3.00	19.00	3-3V	49	1.46	4.12	6.00	4-3V
12	6.03	3.15	19.00	3-3V	50	1.43	5.60	8.00	3-3V
12	6.00	3.00	18.00	3-A	50	1.43	4.20	6.00	4-A
14	5.00	2.80	14.00	3-3V	51	1.42	4.80	6.80	3-B
14	5.00	3.00	15.00	3-A	52	1.38	5.00	6.90	3-3V
15	4.69	3.20	15.00	3-A	52	1.38	4.80	6.60	3-B
15	4.67	3.00	14.00	3-3V	53	1.36	4.12	5.60	4-3V
16	4.44	3.15	14.00	3-3V	53	1.36	5.00	6.80	3-B
16	4.41	3.40	15.00	3-A	55	1.31	5.20	6.80	3-B
17	4.29	4.20	18.00	2-A	55	1.30	5.00	6.50	3-3V
17	4.22	4.50	19.00	2-3V	56	1.29	4.12	5.30	4-3V
18	4.00	2.65	10.60	3-3V	56	1.29	4.80	6.20	3-B
18	4.00	3.00	12.00	3-A	57	1.27	7.40	9.40	2-B
19	3.84	3.65	14.00	2-3V	57	1.26	4.75	6.00	4-3V
19	3.75	3.20	12.00	3-A	58	1.24	5.00	6.20	3-B
20	3.53	3.00	10.60	4-3V	58	1.23	5.30	6.50	3-3V
20	3.53	3.00	10.60	4-A	59	1.21	4.12	5.00	4-3V
21	3.41	5.40	18.40	2-B	59	1.21	4.80	5.80	3-B
21	3.37	3.15	10.60	4-3V	60	1.20	5.00	6.00	3-3V
23	3.17	6.00	19.00	2-3V	60	1.20	5.00	6.00	3-B
23	3.08	5.00	15.40	2-B	60	1.19	5.40	6.40	3-B
24	2.94	3.60	10.60	3-A	61	1.18	4.50	5.30	4-3V
25	2.90	3.65	10.60	3-3V	62	1.16	7.40	8.60	2-B
25	2.85	5.40	15.40	2-B	62	1.15	4.12	4.75	4-3V
26	2.80	5.00	14.00	2-3V	64	1.13	4.80	5.40	3-B
26	2.79	3.80	10.60	3-A	64	1.12	5.00	5.60	3-3V
26	2.75	6.90	19.00	2-3V	65	1.11	4.50	5.00	4-3V
27	2.67	3.00	8.00	4-3V	65	1.11	5.40	6.00	3-B
27	2.65	4.00	10.60	3-A	66	1.09	4.12	4.50	4-3V
28	2.58	4.80	12.40	2-B	66	1.08	4.80	5.20	3-B
28	2.54	3.15	8.00	4-3V	67	1.07	5.60	6.00	4-3V
29	2.50	5.60	14.00	2-3V	68	1.06	6.20	6.60	3-B
29	2.48	5.00	12.40	2-B	68	1.06	5.00	5.30	4-3V
30	2.39	3.35	8.00	3-3V	68	1.06	6.40	6.80	3-B
30	2.38	5.20	12.40	2-B	69	1.04	5.00	5.20	4-B
31	2.28	3.60	8.20	4-A	70	1.03	6.20	6.40	3-B
32	2.23	4.75	10.60	3-3V	72	1.00	5.00	5.00	4-3V
32	2.21	4.80	10.60	3-A	72	1.00	6.20	6.20	3-B
33	2.19	3.65	8.00	4-3V	74	0.97	6.40	6.20	3-B
34	2.12	5.00	10.60	3-3V	75	0.96	5.00	4.80	4-B
34	2.12	5.00	10.60	3-A	76	0.94	6.40	6.00	3-B
35	2.06	3.35	6.90	4-3V	77	0.93	6.00	5.60	4-3V
35	2.04	4.60	9.40	3-B	78	0.92	4.50	4.12	5-3V
36	2.00	3.00	6.00	5-3V	78	0.92	5.20	4.80	4-B
36	2.00	6.20	12.40	2-B	79	0.91	6.60	6.00	3-B
37	1.94	4.12	8.00	3-3V	80	0.90	5.30	4.75	4-3V
37	1.94	6.40	12.40	2-B	81	0.89	5.60	5.00	4-B
38	1.88	6.60	12.40	2-B	82	0.88	6.00	5.30	4-3V
38	1.87	3.00	5.60	5-3V	82	0.88	5.20	4.60	4-B
39	1.82	6.80	12.40	2-B	82	0.88	6.60	5.80	3-B
40	1.78	4.50	8.00	3-3V	83	0.87	6.90	6.00	3-3V
41	1.77	6.20	11.00	2-B	83	0.86	5.80	5.00	4-B
41	1.75	8.00	14.00	2-3V	84	0.85	6.80	5.80	3-B
41	1.74	5.40	9.40	3-B	84	0.85	5.60	4.75	4-3V
43	1.67	4.12	6.90	4-3V	85	0.84	6.40	5.40	4-A
43	1.68	7.40	12.40	2-B	86	0.83	6.00	5.00	4-3V
44	1.63	6.50	10.60	3-3V					
44	1.62	5.80	9.40	3-B					
45	1.60	5.00	8.00	3-3V					
45	1.59	5.40	8.60	3-B					
46	1.55	5.80	9.00	3-A					
47	1.54	4.80	7.40	3-B					
48	1.51	5.30	8.00	3-3V					

Every effort has been taken to ensure that the data listed in this catalogue is correct. Challenge accepts no liability for any inaccuracies or damage caused.

All dimensions in inches unless otherwise stated.

Shaft Mounted Speed Reducer

Belt Drives for 1750 rpm motors

TXT 515 Driven by 1750 rpm Motors									
Out-put rpm	V-belt Drive Ratio	Sheave Diameters		Qty. & Belt Size	Out-put rpm	V-belt Drive Ratio	Sheave Diameters		Qty. & Belt Size
		Motor	Reducer				Motor	Reducer	
14	8.33	3.00	25.00	4-3V	66	1.71	4.80	8.20	6-A
14	8.26	4.60	38.00	3-B	68	1.68	4.75	8.00	6-3V
14	7.94	3.15	25.00	3-3V	68	1.68	7.40	12.40	3-B
15	7.46	3.35	25.00	3-3V	68	1.66	7.10	11.80	3-5V
17	6.85	3.65	25.00	3-3V	70	1.62	5.80	9.40	4-B
17	6.52	4.60	30.00	3-B	71	1.60	5.00	8.00	5-3V
19	6.03	3.15	19.00	3-3V	71	1.59	5.40	8.60	5-B
19	6.00	3.00	18.00	4-A	72	1.57	6.00	9.40	4-B
20	5.67	3.35	19.00	4-3V	74	1.54	6.90	10.60	4-3V
20	5.63	3.20	18.00	5-A	74	1.54	5.60	8.60	4-B
21	5.29	3.40	18.00	5-A	76	1.49	7.40	11.00	4-B
22	5.26	4.75	25.00	3-3V	77	1.48	8.00	11.80	3-5V
22	5.21	3.65	19.00	4-3V	77	1.47	6.40	9.40	4-B
22	5.21	4.80	25.00	3-B	78	1.46	5.60	8.20	6-A
24	4.74	3.80	18.00	4-A	78	1.45	4.75	6.90	8-3V
25	4.61	4.12	19.00	3-3V	80	1.42	6.60	9.40	4-B
25	4.50	4.00	18.00	4-A	81	1.40	11.00	15.40	3-B
26	4.44	3.15	14.00	5-3V	82	1.38	5.00	6.90	6-3V
26	4.31	5.80	25.00	3-B	82	1.38	6.80	9.40	4-B
26	4.29	4.20	18.00	5-A	84	1.36	5.00	6.80	6-B
27	4.22	4.50	19.00	4-3V	84	1.35	9.25	12.50	3-5V
28	4.00	4.75	19.00	3-3V	85	1.34	6.40	8.60	4-B
28	4.09	4.40	18.00	4-A	85	1.33	6.00	8.00	5-3V
30	3.80	5.00	19.00	3-3V	85	1.33	8.00	10.60	4-3V
30	3.75	4.80	18.00	4-A	86	1.32	9.40	12.40	3-B
31	3.68	5.00	18.40	3-B	88	1.29	8.00	10.30	3-5V
32	3.58	5.30	19.00	3-3V	88	1.29	7.00	9.00	5-A
32	3.54	5.20	18.40	3-B	89	1.27	7.10	9.00	3-5V
34	3.35	4.60	15.40	4-B	89	1.27	7.40	9.40	4-B
35	3.26	4.60	15.00	4-A	90	1.26	4.75	6.00	8-3V
36	3.13	4.80	15.00	4-A	90	1.26	6.80	8.60	5-B
37	3.11	4.50	14.00	4-3V	91	1.25	5.60	7.00	6-A
37	3.08	5.00	15.40	3-B	92	1.23	5.30	6.50	6-3V
39	2.92	6.50	19.00	3-3V	93	1.22	5.40	6.60	5-B
39	2.88	5.20	15.00	4-A	94	1.21	8.50	10.30	3-5V
40	2.85	5.40	15.40	4-B	94	1.21	5.60	6.80	6-B
41	2.80	5.00	14.00	4-3V	95	1.20	7.50	9.00	3-5V
42	2.70	4.60	12.40	5-B	95	1.19	6.20	7.40	5-B
43	2.64	5.30	14.00	4-3V	97	1.17	9.40	11.00	4-B
43	2.66	5.80	15.40	4-B	99	1.15	6.00	6.90	6-3V
44	2.58	4.80	12.40	4-B	100	1.14	5.60	6.40	6-B
46	2.48	6.20	15.40	3-B	101	1.13	5.30	6.00	8-3V
47	2.41	6.40	15.40	3-B	101	1.13	6.00	6.80	6-B
48	2.38	5.20	12.40	4-B	102	1.11	9.25	10.30	3-5V
48	2.36	4.50	10.60	5-3V	102	1.11	5.40	6.00	6-B
49	2.33	6.60	15.40	3-B	102	1.11	9.50	10.50	3-C
51	2.23	4.75	10.60	5-3V	103	1.10	6.20	6.80	5-B
51	2.21	5.60	12.40	4-B	104	1.09	8.50	9.25	3-5V
52	2.20	5.00	11.00	4-B	105	1.08	6.00	6.50	6-3V
53	2.14	5.80	12.40	4-B	105	1.08	12.00	13.00	3-C
54	2.12	5.00	10.60	4-3V	107	1.06	6.50	6.90	5-3V
54	2.12	5.20	11.00	4-B	107	1.06	6.20	6.60	5-B
55	2.07	5.80	12.00	4-A	110	1.03	6.20	6.40	5-B
57	2.00	5.30	10.60	4-3V	110	1.03	9.00	9.25	3-5V
57	2.00	6.20	12.40	3-B	117	0.97	9.25	9.00	3-5V
58	1.96	5.60	11.00	4-B	117	0.97	6.40	6.20	5-B
59	1.94	6.40	12.40	4-B	120	0.95	10.50	10.00	3-C
60	1.90	5.80	11.00	4-B	121	0.94	9.00	8.50	3-5V
60	1.89	5.60	10.60	5-3V	121	0.94	9.00	8.50	3-C
62	1.83	6.00	11.00	4-B	122	0.93	6.00	5.60	6-3V
63	1.79	10.60	19.00	3-3V	122	0.93	6.00	5.60	6-B
63	1.79	4.80	8.60	5-B	124	0.92	6.50	6.00	6-3V
65	1.75	8.00	14.00	3-3V	124	0.92	13.00	12.00	3-C
65	1.74	5.40	9.40	5-B	124	0.92	9.25	8.50	3-5V
66	1.72	6.40	11.00	4-B	125	0.91	9.40	8.60	4-B

TXT 525 Driven by 1750 rpm Motors									
Out-put rpm	V-belt Drive Ratio	Sheave Diameters		Qty. & Belt Size	Out-put rpm	V-belt Drive Ratio	Sheave Diameters		Qty. & Belt Size
		Motor	Reducer				Motor	Reducer	
10	6.79	2.80	19.00	3-3V	48	1.43	6.00	8.60	3-B
11	6.33	3.00	19.00	3-3V	49	1.39	6.20	8.60	3-B
11	6.00	3.00	18.00	3-A	50	1.38	5.00	6.90	4-3V
12	5.67	3.35	19.00	3-3V	50	1.38	4.80	6.60	4-B
12	5.63	3.20	18.00	4-A	50	1.37	4.75	6.50	5-3V
13	5.29	3.40	18.00	4-A	51	1.33	4.50	6.00	5-3V
13	5.21	3.65	19.00	3-3V	51	1.33	4.80	6.40	4-B
14	5.00	3.00	15.00	4-A	52	1.32	5.00	6.60	4-B
15	4.69	3.20	15.00	4-A	53	1.30	5.30	6.90	4-3V
15	4.67	3.00	14.00	4-3V	53	1.30	5.00	6.50	4-3V
15	4.44	3.15	14.00	4-3V	53	1.29	4.80	6.20	4-B
16	4.41	3.40	15.00	4-A	54	1.26	4.75	6.00	5-3V
16	4.18	3.35	14.00	3-3V	54	1.26	6.80	8.60	3-B
17	4.00	4.75	19.00	2-3V	55	1.25	4.80	6.00	4-B
17	3.95	3.80	15.00	3-A	56	1.23	5.60	6.90	4-3V
19	3.53	3.00	10.60	4-3V	57	1.21	4.80	5.80	4-B
19	3.53	3.00	10.60	4-A	57	1.20	5.00	6.00	4-3V
20	3.37	3.15	10.60	5-3V	58	1.19	5.40	6.40	4-B
20	3.35	4.60	15.40	3-B	59	1.16	7.40	8.60	3-B
21	3.33	3.60	12.00	4-A	60	1.15	6.00	6.90	4-3V
22	3.16	3.35	10.60	4-3V	60	1.14	5.60	6.40	4-B
22	3.16	3.80	12.00	4-A	61	1.13	5.30	6.00	5-3V
22	3.11	4.50	14.00	3-3V	61	1.13	7.10	8.00	3-5V
23	2.94	3.60	10.60	4-A	61	1.13	4.80	5.40	5-B
24	2.90	3.65	10.60	4-3V	62	1.11	5.60	6.20	4-B
24	2.88	6.40	18.40	2-B	63	1.09	8.60	9.40	3-B
24	2.80	5.00	14.00	3-3V	63	1.08	6.00	6.50	4-3V
25	2.70	4.60	12.40	3-B	64	1.07	5.80	6.20	4-B
26	2.67	3.00	8.00	5-3V	65	1.06	6.50	6.90	4-3V
26	2.65	4.00	10.60	4-A	65	1.06	7.10	7.50	3-5V
27	2.57	4.12	10.60	3-3V	65	1.06	8.50	9.00	3-C
27	2.50	5.60	14.00	3-3V	66	1.03	5.80	6.00	4-B
27	2.50	4.80	12.00	4-A	68	1.00	6.50	6.50	4-3V
28	2.48	5.00	12.40	3-B	68	1.00	5.80	5.80	4-B
29	2.38	5.20	12.40	3-B	71	0.97	6.00	5.80	4-B
29	2.36	4.50	10.60	4-3V	72	0.95	7.50	7.10	3-5V
31	2.20	5.00	11.00	3-B	73	0.94	9.00	8.50	3-C
32	2.12	5.00	10.60	3-3V	74	0.93	5.80	5.40	5-B
32	2.12	5.20	11.00	3-B	74	0.92	6.50	6.00	4-3V
33	2.07	5.80	12.00	3-A	75	0.91	6.60	6.00	4-B
34	2.04	5.40	11.00	3-B	76	0.90	6.00	5.40	4-B
34	2.00	5.30	10.60	3-3V	77	0.89	8.00	7.10	3-5V
35	1.96	4.80	9.40	3-B	77	0.89	7.40	6.60	4-B
35	1.94	4.12	8.00	4-3V	78	0.88	6.40	5.60	5-B
36	1.89	5.60	10.60	3-3V	79	0.87	8.60	7.50	3-5V
36	1.88	5.00	9.40	3-B	80	0.86	8.00	6.90	4-3V
37	1.83	5.80	10.60	3-A	80	0.86	7.40	6.40	4-B
38	1.79	4.80	8.60	3-B	81	0.85	11.00	9.40	3-B
38	1.78	4.50	8.00	4-3V					
39	1.75	8.00	14.00	2-3V					
39	1.74	5.40	9.40	3-B					
40	1.72	5.00	8.60	3-B					
41	1.68	4.75	8.00	4-3V					
41	1.68	7.40	12.40	2-B					
41	1.67	4.12	6.90	4-3V					
42	1.63	6.50	10.60	3-3V					
42	1.62	6.80	11.00	3-B					
44	1.57	6.00	9.40	3-B					
45	1.53	4.50	6.90	5-3V					
45	1.52	6.20	9.40	3-B					
45	1.51	5.30	8.00	4-3V					
46	1.48	5.00	7.40	4-B					
47	1.47	6.40	9.40	3-B					
48	1.44	4.50	6.50	5-3V					
48	1.43	5.60	8.00	4-3V					

All dimensions in inches unless otherwise stated. Every effort has been taken to ensure that the data listed in this catalogue is correct. Challenge accepts no liability for any inaccuracies or damage caused.

Shaft Mounted Speed Reducer

Belt Drives for 1750 rpm motors

TXT 615 Driven by 1750 rpm Motors									
Out-put rpm	V-belt Drive Ratio	Sheave Diameters		Qty. & Belt Size	Out-put rpm	V-belt Drive Ratio	Sheave Diameters		Qty. & Belt Size
		Motor	Reducer				Motor	Reducer	
10	11.17	3.00	33.50	4-3V	67	1.71	7.00	12.00	6-A
11	10.63	3.15	33.50	4-3V	68	1.67	7.50	12.50	3-5V
12	9.18	3.65	33.50	4-3V	68	1.67	6.60	11.00	5-B
14	8.33	3.00	25.00	5-3V	69	1.66	6.40	10.60	8-A
15	7.60	5.00	38.00	3-B	69	1.65	8.00	13.20	3-5V
15	7.46	3.35	25.00	4-3V	70	1.62	6.80	11.00	5-B
16	7.31	5.20	38.00	3-B	72	1.59	5.40	8.60	6-B
17	6.79	5.60	38.00	3-B	73	1.57	7.50	11.80	3-5V
18	6.25	4.80	30.00	4-B	73	1.57	6.00	9.40	5-B
20	5.77	5.20	30.00	3-B	73	1.56	8.00	12.50	3-5V
21	5.56	4.50	25.00	4-3V	74	1.54	6.90	10.60	5-3V
21	5.43	4.60	25.00	4-B	74	1.54	5.60	8.60	6-B
22	5.21	4.80	25.00	4-B	75	1.52	6.20	9.40	5-B
23	5.00	5.00	25.00	3-3V	76	1.51	5.30	8.00	8-3V
23	5.00	5.00	25.00	3-B	76	1.50	12.00	18.00	4-A
24	4.74	3.80	18.00	5-A	77	1.49	7.40	11.00	4-B
24	4.72	5.30	25.00	3-3V	77	1.48	8.00	11.80	3-5V
25	4.63	5.40	25.00	4-B	79	1.44	9.75	14.00	3-5V
26	4.46	5.60	25.00	4-3V	79	1.44	8.60	12.40	4-B
26	4.35	4.60	20.00	5-B	80	1.43	5.60	8.00	6-3V
27	4.22	4.50	19.00	5-3V	80	1.43	6.00	8.60	5-B
27	4.17	4.80	20.00	5-B	80	1.42	10.60	15.00	6-A
29	4.00	4.60	18.40	5-B	81	1.40	11.00	15.40	4-B
30	3.80	5.00	19.00	4-3V	82	1.39	8.50	11.80	3-5V
30	3.75	4.80	18.00	5-A	83	1.38	6.80	9.40	6-B
31	3.68	5.00	18.40	4-B	83	1.37	7.10	9.75	4-5V
32	3.62	6.90	25.00	3-3V	85	1.34	6.40	8.60	6-B
32	3.58	5.30	19.00	4-3V	86	1.33	6.00	8.00	8-3V
32	3.54	5.20	18.40	4-B	86	1.33	8.00	10.60	5-3V
33	3.41	5.40	18.40	4-B	86	1.33	9.00	12.00	6-A
34	3.39	5.60	19.00	4-3V	86	1.32	9.40	12.40	5-B
34	3.35	4.60	15.40	5-B	87	1.31	9.00	11.80	3-5V
35	3.29	5.60	18.40	4-B	88	1.30	7.50	9.75	4-5V
37	3.07	6.00	18.40	4-B	88	1.30	10.00	13.00	3-C
38	2.97	6.20	18.40	4-B	89	1.28	9.25	11.80	3-5V
39	2.96	5.20	15.40	5-B	89	1.28	8.60	11.00	5-B
39	2.95	4.75	14.00	6-3V	91	1.25	12.00	15.00	5-A
39	2.92	6.50	19.00	4-3V	92	1.24	12.40	15.40	4-B
40	2.88	6.40	18.40	4-B	93	1.23	7.50	9.25	4-5V
41	2.80	5.00	14.00	5-3V	93	1.23	6.50	8.00	8-3V
41	2.79	6.60	18.40	4-B	93	1.23	6.00	7.40	8-B
41	2.75	6.90	19.00	4-3V	94	1.21	9.00	10.90	3-5V
42	2.71	6.80	18.40	4-B	94	1.21	7.00	8.50	5-C
44	2.57	6.00	15.40	4-B	95	1.20	7.10	8.50	4-5V
45	2.53	9.50	24.00	3-C	95	1.20	10.00	12.00	3-C
46	2.50	5.60	14.00	5-3V	96	1.19	11.80	14.00	3-5V
46	2.49	7.40	18.40	4-B	96	1.19	8.00	9.50	4-C
47	2.41	6.40	15.40	5-B	98	1.16	6.90	8.00	6-3V
48	2.38	8.00	19.00	4-3V	98	1.16	7.40	8.60	5-B
48	2.38	5.20	12.40	6-B	98	1.16	6.40	7.40	6-B
49	2.33	6.00	14.00	5-3V	99	1.15	6.00	6.90	8-3V
49	2.33	6.60	15.40	4-B	100	1.14	9.00	10.30	3-5V
51	2.25	8.00	18.00	3-C	100	1.14	10.50	12.00	3-C
51	2.23	4.75	10.60	8-3V	101	1.13	7.10	8.00	4-5V
52	2.21	5.60	12.40	5-B	101	1.13	11.00	12.40	4-B
53	2.15	6.50	14.00	5-3V	103	1.11	9.00	10.00	4-C
53	2.14	5.80	12.40	5-B	105	1.09	8.60	9.40	5-B
54	2.12	5.00	10.60	6-3V	105	1.09	11.00	12.00	4-C
54	2.12	5.20	11.00	6-B	106	1.08	10.90	11.80	3-5V
55	2.07	6.00	12.40	5-B	106	1.08	13.00	14.00	3-C
56	2.04	5.40	11.00	5-B	107	1.07	14.00	15.00	3-5V
56	2.03	6.90	14.00	4-3V	107	1.07	7.50	8.00	5-C
58	1.96	5.60	11.00	6-B	108	1.06	8.00	8.50	4-5V
59	1.94	10.90	21.20	3-5V	109	1.05	10.00	10.50	4-C
59	1.94	6.40	12.40	5-B	111	1.03	9.00	9.25	4-5V
60	1.89	5.60	10.60	6-3V	114	1.00	10.60	10.60	5-3V
60	1.89	9.50	18.00	3-C	114	1.00	9.40	9.40	5-B
61	1.88	6.60	12.40	5-B	118	0.97	9.25	9.00	4-5V
61	1.87	7.50	14.00	3-5V	121	0.94	10.90	10.30	3-5V
62	1.83	6.00	11.00	6-B	121	0.94	6.80	6.40	8-B
63	1.82	6.80	12.40	5-B	121	0.94	8.00	7.50	5-5V
64	1.77	6.00	10.60	6-3V	121	0.94	8.00	7.50	5-C
64	1.77	6.20	11.00	5-B	123	0.93	14.00	13.00	3-C
66	1.73	9.25	16.00	3-5V	124	0.92	11.80	10.90	3-5V
66	1.72	6.40	11.00	5-B	124	0.92	7.40	6.80	8-B

TXT 625 Driven by 1750 rpm Motors									
Out-put rpm	V-belt Drive Ratio	Sheave Diameters		Qty. & Belt Size	Out-put rpm	V-belt Drive Ratio	Sheave Diameters		Qty. & Belt Size
		Motor	Reducer				Motor	Reducer	
10	6.85	3.65	25.00	3-3V	57	1.23	5.30	6.50	6-3V
11	6.52	4.60	30.00	3-B	57	1.22	5.40	6.60	5-V
12	6.03	3.15	19.00	3-3V	58	1.20	7.50	9.00	3-5V
12	5.67	3.35	19.00	4-3V	58	1.19	6.20	7.40	5-B
12	5.63	3.20	18.00	5-A	60	1.16	5.60	6.50	6-3V
14	5.00	5.00	25.00	3-3V	60	1.16	7.40	8.60	4-B
14	5.00	3.60	18.00	5-A	61	1.14	5.60	6.40	6-B
15	4.74	3.80	18.00	4-A	62	1.13	7.50	8.50	3-5V
15	4.61	4.12	19.00	3-3V	62	1.13	8.00	9.00	3-5V
16	4.29	4.20	18.00	4-A	62	1.13	11.00	12.40	3-B
17	4.18	3.35	14.00	4-3V	63	1.10	6.20	6.80	5-B
17	4.09	4.40	18.00	4-A	64	1.09	8.60	9.40	4-B
17	4.00	4.75	19.00	3-3V	64	1.08	6.00	6.50	6-3V
18	3.91	4.60	18.00	4-A	65	1.07	7.50	8.00	3-5V
18	3.80	5.00	19.00	3-3V	66	1.06	6.20	6.60	5-B
19	3.68	5.00	18.40	3-B	66	1.06	6.50	6.90	5-3V
19	3.58	5.30	19.00	3-3V	68	1.03	6.20	6.40	5-B
21	3.26	4.60	15.00	4-A	68	1.03	9.00	9.25	3-5V
22	3.13	4.80	15.00	4-A	68	1.03	6.40	6.60	5-B
22	3.11	4.50	14.00	4-3V	70	1.00	6.00	6.00	6-3V
23	3.08	5.00	15.40	3-B	70	1.00	11.00	11.00	3-B
24	2.96	5.20	15.40	3-B	72	0.97	9.25	9.00	3-5V
24	2.95	4.75	14.00	4-3V	72	0.97	6.40	6.20	5-B
24	2.92	6.50	19.00	3-3V	73	0.95	9.75	9.25	3-5V
25	2.80	5.00	14.00	3-3V	73	0.95	10.00	9.50	3-C
25	2.75	5.60	15.40	3-B	74	0.94	6.90	6.50	5-3V
26	2.66	5.80	15.40	4-B	74	0.94	6.40	6.00	5-B
26	2.64	5.30	14.00	4-3V	76	0.92	6.50	6.00	6-3V
27	2.58	4.80	12.40	4-B	76	0.92	9.25	8.50	3-5V
28	2.50	5.60	14.00	4-3V	76	0.91	6.80	6.20	5-B
28	2.48	6.20	15.40	3-B	76	0.91	6.60	6.00	5-B
30	2.33	6.00	14.00	4-3V	78	0.89	9.00	8.00	3-5V
30	2.29	4.80	11.00	4-B	78	0.89	7.40	6.60	5-B
31	2.26	6.80	15.40	3-B	78	0.89	8.00	7.10	3-5V
31	2.23	4.75	10.60	5-3V	79	0.88	6.80	6.00	5-B
32	2.20	5.00	11.00	4-B	79	0.88	8.00	7.00	4-C
32	2.15	6.50	14.00	3-3V	80	0.87	6.90	6.00	5-3V
33	2.12	5.00	10.60	4-3V					
33	2.12	5.20	11.00	4-B					
34	2.04	5.40	11.00	4-B					
34	2.03	6.90	14.00	3-3V					
36	1.96	4.80	9.40	5-B					
37	1.90	5.80	11.00	4-B					
37	1.89	5.60	10.60	5-3V					
38	1.83	6.00	11.00	4-B					
39	1.77	6.00	10.60	4-3V					
39	1.77	6.20	11.00	4-B					
40	1.75	8.00	14.00	3-3V					
40	1.72	5.00	8.60	5-B					
41	1.68	7.40	12.40	3-B					
42	1.66	7.10	11.80	3-5V					
43	1.62	5.80	9.40	4-B					
44	1.60	5.00	8.00	5-3V					
44	1.57	7.50	11.80	3-5V					
44	1.57	6.00	9.40	4-B					
45	1.54	6.90	10.60	4-3V					
45	1.54	5.60	8.60	4-B					
46	1.52	6.20	9.40	5-B					
46	1.51	5.30	8.00	6-3V					
48	1.45	4.75	6.90	8-3V					
48	1.								

Shaft Mounted Speed Reducer

Belt Drives for 1750 rpm motors

TXT 715 Driven by 1750 rpm Motors									
Out-put rpm	V-belt Drive Ratio	Sheave Diameters		Qty. & Belt Size	Out-put rpm	V-belt Drive Ratio	Sheave Diameters		Qty. & Belt Size
		Motor	Reducer				Motor	Reducer	
10	11.17	3.00	33.50	5-3V	63	1.82	6.80	12.40	6-B
10	11.17	3.00	33.50	5-3V	65	1.78	9.00	16.00	4-C
14	8.26	4.60	38.00	4-B	66	1.75	8.00	14.00	6-3V
14	8.13	4.12	33.50	4-3V	67	1.71	7.00	12.00	6-C
16	7.31	5.20	38.00	3-B	68	1.70	12.50	21.20	3-5V
17	6.79	5.60	38.00	4-3V	68	1.68	9.50	16.00	4-C
17	6.79	5.60	38.00	4-B	69	1.67	11.00	18.40	5-B
18	6.32	5.30	33.50	4-3V	70	1.65	8.00	13.20	4-5V
18	6.25	4.80	30.00	5-B	70	1.64	9.75	16.00	3-5V
20	5.77	5.20	30.00	4-B	70	1.64	9.40	15.40	5-B
21	5.56	4.50	25.00	5-3V	72	1.60	7.50	12.00	5-C
21	5.43	4.60	25.00	5-B	73	1.57	7.00	11.00	6-C
22	5.26	4.75	25.00	5-3V	74	1.56	8.00	12.50	4-5V
22	5.17	5.80	30.00	5-B	75	1.54	6.90	10.60	8-3V
23	5.00	5.00	25.00	5-3V	75	1.54	13.00	20.00	3-C
23	5.00	5.00	25.00	5-B	76	1.51	9.25	14.00	4-5V
25	4.63	5.40	25.00	5-B	77	1.49	7.40	11.00	6-B
26	4.46	5.60	25.00	5-3V	78	1.48	8.00	11.80	4-5V
26	4.46	5.60	25.00	5-B	78	1.47	7.50	11.00	5-C
27	4.31	5.80	25.00	5-B	79	1.46	10.30	15.00	3-5V
28	4.17	6.00	25.00	4-3V	79	1.45	11.00	16.00	4-C
29	4.00	5.00	20.00	5-B	80	1.44	8.60	12.40	6-B
29	3.94	7.10	28.00	3-5V	80	1.43	9.25	13.20	4-5V
30	3.85	5.20	20.00	6-B	81	1.41	8.50	12.00	5-C
30	3.80	5.00	19.00	6-3V	82	1.40	11.00	15.40	5-B
31	3.68	5.00	18.40	6-B	83	1.39	8.50	11.80	4-5V
33	3.50	8.00	28.00	3-5V	84	1.37	9.50	13.00	5-C
33	3.45	5.80	20.00	5-B	84	1.36	8.00	10.90	5-5V
34	3.41	5.40	18.40	8-B	84	1.36	11.80	16.00	3-5V
34	3.39	5.60	19.00	6-3V	86	1.33	7.50	10.00	6-C
35	3.29	8.50	28.00	3-5V	88	1.31	8.00	10.50	5-C
35	3.29	5.60	18.40	6-B	88	1.30	7.50	9.75	5-5V
36	3.19	9.40	30.00	4-B	89	1.29	8.50	11.00	5-C
36	3.17	6.00	19.00	6-3V	90	1.28	9.75	12.50	4-5V
38	3.03	6.60	20.00	5-B	90	1.27	7.50	9.50	6-C
38	2.99	7.10	21.20	4-5V	93	1.24	12.40	15.40	5-B
39	2.94	6.80	20.00	5-B	93	1.24	8.50	10.50	5-C
39	2.92	6.50	19.00	5-3V	93	1.23	7.50	9.25	5-5V
41	2.79	6.60	18.40	5-B	94	1.22	8.00	9.75	5-5V
42	2.75	6.90	19.00	5-3V	94	1.22	9.00	11.00	5-C
42	2.71	6.80	18.40	5-B	95	1.21	9.00	10.90	4-5V
43	2.70	7.40	20.00	5-B	96	1.20	7.50	9.00	5-5V
44	2.64	5.30	14.00	8-3V	96	1.20	10.00	12.00	4-C
46	2.50	5.60	14.00	6-3V	97	1.18	9.25	10.90	4-5V
46	2.48	6.20	15.40	5-B	97	1.18	11.00	13.00	4-C
47	2.42	12.40	30.00	3-B	98	1.17	9.40	11.00	6-B
48	2.41	6.40	15.40	5-B	101	1.14	9.00	10.30	4-5V
48	2.38	8.00	19.00	4-3V	101	1.14	10.50	12.00	4-C
50	2.29	9.25	21.20	3-5V	102	1.13	7.50	8.50	5-5V
50	2.29	10.50	24.00	3-C	102	1.13	11.00	12.40	5-B
51	2.26	6.80	15.40	6-B	103	1.12	12.50	14.00	3-5V
51	2.25	7.10	16.00	4-5V	103	1.12	11.80	13.20	3-5V
52	2.20	8.20	18.00	8-A	103	1.12	8.50	9.50	5-C
53	2.18	11.00	24.00	3-C	104	1.11	9.50	10.50	5-C
53	2.15	6.50	14.00	8-3V	105	1.09	11.00	12.00	5-C
55	2.08	7.40	15.40	6-B	106	1.08	13.00	14.00	4-C
56	2.07	6.00	12.40	8-B	107	1.07	14.00	15.00	3-5V
57	2.03	6.90	14.00	6-3V	108	1.06	10.30	10.90	4-5V
58	1.97	7.10	14.00	4-5V	109	1.05	9.25	9.75	5-5V
59	1.94	10.90	21.20	3-5V	109	1.05	10.00	10.50	5-C
59	1.94	6.40	12.40	6-B	109	1.05	10.50	11.00	5-C
60	1.90	10.50	20.00	3-C	112	1.03	9.00	9.25	5-5V
61	1.88	8.50	16.00	3-5V	115	1.00	10.30	10.30	4-5V
61	1.88	8.50	16.00	4-C	115	1.00	11.00	11.00	6-B
62	1.86	7.00	13.00	5-C	118	0.97	9.25	9.00	5-5V

TXT 725 Driven by 1750 rpm Motors									
Out-put rpm	V-belt Drive Ratio	Sheave Diameters		Qty. & Belt Size	Out-put rpm	V-belt Drive Ratio	Sheave Diameters		Qty. & Belt Size
		Motor	Reducer				Motor	Reducer	
10	7.31	5.20	38.00	3-B	49	1.45	7.50	10.90	3-5V
10	6.85	3.65	25.00	4-3V	49	1.44	8.60	12.40	4-B
11	6.52	4.60	30.00	4-B	49	1.43	9.25	13.20	3-5V
12	6.07	4.12	25.00	4-3V	49	1.43	6.00	8.60	8-B
12	6.00	5.00	30.00	3-B	50	1.40	11.00	15.40	4-B
13	5.43	4.60	25.00	4-B	51	1.39	8.50	11.80	3-5V
13	5.26	4.75	25.00	3-3V	51	1.37	7.10	9.75	4-5V
14	5.00	5.00	25.00	3-3V	52	1.36	7.00	9.50	5-C
14	5.00	5.00	25.00	3-B	53	1.34	6.40	8.60	6-B
15	4.74	3.80	18.00	5-A	53	1.33	6.00	8.00	8-3V
15	4.61	4.12	19.00	4-3V	53	1.33	8.00	10.60	5-3V
16	4.50	4.00	18.00	5-A	53	1.32	9.40	12.40	5-B
16	4.46	5.60	25.00	3-3V	55	1.28	9.25	11.80	3-5V
17	4.22	4.50	19.00	5-3V	55	1.27	7.40	9.40	5-B
17	4.17	4.80	20.00	5-B	57	1.24	12.40	15.40	4-B
18	4.00	4.75	19.00	4-3V	57	1.23	6.50	8.00	8-3V
18	4.00	4.60	18.40	5-B	57	1.23	6.00	7.40	8-B
20	3.58	5.30	19.00	4-3V	58	1.21	9.00	10.90	3-5V
20	3.54	5.20	18.40	4-B	59	1.20	10.00	12.00	3-C
21	3.41	5.40	18.40	4-B	60	1.18	9.25	10.90	3-5V
21	3.39	5.60	19.00	4-3V	60	1.18	9.00	10.60	6-A
21	3.29	5.60	18.40	4-B	61	1.16	6.90	8.00	6-3V
22	3.17	6.00	19.00	4-3V	61	1.16	7.40	8.60	5-B
23	3.13	8.00	25.00	3-3V	61	1.16	6.40	7.40	6-B
23	3.07	6.00	18.40	4-B	61	1.15	6.00	6.90	8-3V
24	2.97	6.20	18.40	4-B	62	1.13	7.10	8.00	4-5V
24	2.92	6.50	19.00	4-3V	62	1.13	11.00	12.40	4-B
24	2.88	6.40	18.40	4-B	63	1.12	8.50	9.50	4-C
25	2.80	5.00	14.00	5-3V	63	1.11	9.25	10.30	3-5V
25	2.79	6.60	18.40	4-B	65	1.09	8.50	9.25	4-5V
26	2.75	6.90	19.00	4-3V	65	1.09	8.60	9.40	6-B
26	2.66	5.80	15.40	4-B	66	1.07	7.50	8.00	5-C
27	2.64	5.30	14.00	5-3V	66	1.06	10.30	10.90	3-5V
30	2.33	6.00	14.00	5-3V	67	1.05	9.50	10.00	4-C
30	2.33	6.60	15.40	4-B	68	1.03	9.00	9.25	4-5V
31	2.26	6.80	15.40	4-B	70	1.00	10.60	10.60	5-3V
31	2.25	7.10	16.00	3-5V	70	1.00	9.40	9.40	5-B
32	2.23	4.75	10.60	8-3V	73	0.97	9.25	9.00	4-5V
32	2.21	5.60	12.40	5-B	74	0.95	9.50	9.00	4-C
33	2.14	5.80	12.40	5-B	75	0.94	10.90	10.30	3-5V
33	2.12	5.00	10.60	6-3V	75	0.94	8.50	8.00	4-5V
34	2.07	6.00	12.40	5-B					
35	2.03	6.90	14.00	4-3V					
35	2.04	5.40	11.00	5-B					
35	2.00	6.20	12.40	5-B					
36	1.97	7.10	14.00	3-5V					
37	1.88	6.60	12.40	5-B					
38	1.87	7.50	14.00	3-5V					
39	1.82	6.80	12.40	5-B					
40	1.77	6.00	10.60	6-3V					
40	1.77	6.20	11.00	5-B					
40	1.75	8.00	14.00	4-3V					
41	1.72	6.40	11.00	5-B					
42	1.68	7.40	12.40	5-B					
42	1.67	7.50	12.50	3-5V					
42	1.67	6.60	11.00	5-B					
43	1.65	8.00	13.20	3-5V					
43	1.63	6.50	10.60	5-3V					
43	1.62	6.80	11.00	5-B					
45	1.57	7.50	11.80	3-5V					
45	1.57	6.00	9.40	5-B					
46	1.52	6.20	9.40	5-B					
47	1.51	5.30	8.00	8-3V					
47	1.49	7.40	11.00	4-B					
48	1.48	8.00	11.80	3-5V					

All dimensions in inches unless otherwise stated. Every effort has been taken to ensure that the data listed in this catalogue is correct. Challenge accepts no liability for any inaccuracies or damage caused.

Shaft Mounted Speed Reducer

Belt Drives for 1750 rpm motors

TXT 815 Driven by 1750 rpm Motors									
Out-put rpm	V-belt Drive Ratio	Sheave Diameters		Qty. & Belt Size	Out-put rpm	V-belt Drive Ratio	Sheave Diameters		Qty. & Belt Size
		Motor	Reducer				Motor	Reducer	
14	8.26	4.60	38.00	5-B	62	1.88	8.50	16.00	4-5V
15	7.60	5.00	38.00	4-B	63	1.85	13.00	24.00	4-C
16	7.44	4.50	33.50	4-3V	64	1.80	11.80	21.20	3-5V
16	7.31	5.20	38.00	4-B	64	1.80	10.00	18.00	4-C
16	7.05	4.75	33.50	4-3V	65	1.79	10.60	19.00	6-3V
18	6.33	6.00	38.00	4-B	65	1.79	8.60	15.40	8-B
18	6.32	5.30	33.50	5-3V	66	1.75	8.00	14.00	8-3V
19	6.00	5.00	30.00	5-B	66	1.75	8.00	14.00	6-C
19	5.98	5.60	33.50	4-3V	68	1.71	10.50	18.00	5-C
20	5.77	5.20	30.00	5-B	68	1.70	12.50	21.20	4-5V
21	5.58	6.00	33.50	5-3V	69	1.67	9.00	15.00	5-5V
21	5.56	5.40	30.00	6-B	69	1.67	11.00	18.40	6-B
22	5.26	4.75	25.00	6-3V	69	1.67	12.00	20.00	4-C
22	5.17	5.80	30.00	5-B	71	1.64	9.75	16.00	4-5V
24	4.81	5.20	25.00	6-B	71	1.64	9.40	15.40	8-B
25	4.72	5.30	25.00	6-3V	72	1.62	9.25	15.00	5-5V
25	4.63	5.40	25.00	6-B	73	1.60	10.00	16.00	5-C
26	4.46	5.60	25.00	6-3V	75	1.55	10.30	16.00	4-5V
26	4.46	5.60	25.00	6-B	75	1.54	9.75	15.00	5-5V
27	4.29	7.00	30.00	4-C	75	1.54	13.00	20.00	4-C
29	4.05	7.40	30.00	5-B	76	1.52	10.50	16.00	5-C
29	3.94	7.10	28.00	3-5V	77	1.51	9.25	14.00	5-5V
30	3.91	6.40	25.00	5-B	77	1.50	12.00	18.00	4-C
30	3.85	6.50	25.00	5-3V	78	1.48	12.40	18.40	6-B
31	3.79	6.60	25.00	5-B	80	1.45	11.00	16.00	5-C
31	3.73	7.50	28.00	3-5V	81	1.44	9.75	14.00	4-5V
32	3.58	5.30	19.00	8-3V	81	1.43	14.00	20.00	4-C
33	3.57	5.60	20.00	6-B	83	1.40	11.00	15.40	6-B
34	3.38	7.40	25.00	6-B	83	1.39	9.00	12.50	5-5V
35	3.33	6.00	20.00	8-B	84	1.38	10.90	15.00	4-5V
35	3.29	8.50	28.00	3-5V	84	1.38	13.00	18.00	4-C
36	3.19	9.40	30.00	5-B	86	1.35	9.25	12.50	5-5V
37	3.17	6.00	19.00	8-3V	87	1.33	12.00	16.00	4-C
37	3.13	8.00	25.00	5-3V	88	1.32	10.60	14.00	8-3V
37	3.13	6.40	20.00	8-B	88	1.32	9.40	12.40	8-B
38	3.07	6.00	18.40	8-B	89	1.30	10.00	13.00	5-C
39	2.99	7.10	21.20	4-5V	90	1.29	14.00	18.00	4-C
40	2.88	6.40	18.40	8-B	91	1.28	10.30	13.20	4-5V
40	2.87	9.75	28.00	3-5V	92	1.26	9.50	12.00	5-C
41	2.86	7.00	20.00	5-C	94	1.24	12.40	15.40	6-B
41	2.83	7.50	21.20	4-5V	94	1.24	10.50	13.00	5-C
42	2.75	6.90	19.00	6-3V	96	1.21	10.30	12.50	5-5V
43	2.70	7.40	20.00	8-B	96	1.21	9.00	10.90	6-5V
43	2.67	7.50	20.00	5-C	96	1.21	12.00	14.50	5-D
44	2.65	8.00	21.20	4-5V	97	1.20	12.50	15.00	4-5V
46	2.50	8.00	20.00	5-C	98	1.19	13.00	15.50	5-D
47	2.49	8.50	21.20	4-5V	99	1.17	12.00	14.00	5-C
47	2.49	7.40	18.40	8-B	101	1.15	10.30	11.80	5-5V
48	2.40	7.50	18.00	5-C	101	1.15	13.00	15.00	5-D
49	2.38	8.00	19.00	6-3V	102	1.14	13.20	15.00	4-5V
49	2.35	8.50	20.00	5-C	102	1.14	10.50	12.00	6-C
51	2.27	11.00	25.00	5-B	103	1.13	11.00	12.40	10-B
52	2.25	7.10	16.00	5-5V	106	1.09	11.00	12.00	6-C
52	2.24	12.50	28.00	3-5V	107	1.08	10.90	11.80	5-5V
52	2.22	9.00	20.00	4-C	107	1.08	12.00	13.00	6-C
53	2.18	11.00	24.00	4-C	107	1.08	13.00	14.00	5-C
53	2.17	9.75	21.20	4-5V	108	1.07	14.00	15.00	4-5V
54	2.14	8.60	18.40	8-B	109	1.06	13.20	14.00	4-5V
54	2.13	7.50	16.00	5-5V	109	1.06	12.50	13.20	4-5V
54	2.13	9.40	20.00	6-B	111	1.05	10.50	11.00	6-C
57	2.02	12.40	25.00	5-B	112	1.04	13.00	13.50	5-D
58	2.00	7.50	15.00	5-5V	113	1.03	9.00	9.25	6-5V
59	1.96	9.40	18.40	6-B	116	1.00	14.00	14.00	8-3V
60	1.94	10.90	21.20	4-5V	116	1.00	10.50	10.50	6-C
61	1.90	10.50	20.00	4-C	120	0.97	9.25	9.00	6-5V

TXT 825 Driven by 1750 rpm Motors									
Out-put rpm	V-belt Drive Ratio	Sheave Diameters		Qty. & Belt Size	Out-put rpm	V-belt Drive Ratio	Sheave Diameters		Qty. & Belt Size
		Motor	Reducer				Motor	Reducer	
10	7.31	5.20	38.00	3-B	48	1.49	7.40	11.00	6-B
11	6.52	4.60	30.00	4-B	48	1.48	8.00	11.80	4-5V
12	6.07	4.12	25.00	4-3V	49	1.44	9.75	14.00	3-5V
12	6.00	5.00	30.00	3-B	49	1.44	8.60	12.40	6-B
13	5.43	4.60	25.00	5-B	50	1.43	9.25	13.20	4-5V
14	5.26	4.75	25.00	4-3V	50	1.41	8.50	12.00	4-C
14	5.00	5.00	25.00	4-3V	51	1.40	11.00	15.40	5-B
14	5.00	5.00	25.00	4-B	51	1.39	8.50	11.80	4-5V
16	4.46	5.60	25.00	4-3V	52	1.36	8.00	10.90	4-5V
16	4.35	4.60	20.00	5-B	52	1.36	7.00	9.50	6-C
17	4.17	6.00	25.00	4-3V	53	1.33	7.50	10.00	6-C
17	4.17	6.00	25.00	4-B	53	1.33	8.00	10.60	8-3V
18	4.00	4.75	19.00	5-3V	54	1.32	9.40	12.40	6-B
18	4.00	5.00	20.00	5-B	55	1.30	10.00	13.00	4-C
19	3.80	5.00	19.00	4-3V	56	1.28	12.50	16.00	3-5V
19	3.68	5.00	18.40	5-B	56	1.28	9.25	11.80	4-5V
20	3.58	5.30	19.00	5-3V	56	1.28	8.60	11.00	6-B
20	3.54	5.20	18.40	5-B	57	1.24	12.40	15.40	5-B
21	3.41	5.40	18.40	6-B	57	1.24	8.50	10.50	5-C
21	3.39	5.60	19.00	5-3V	58	1.23	7.50	9.25	5-5V
22	3.29	5.60	18.40	5-B	58	1.22	8.00	9.75	5-5V
22	3.17	6.00	19.00	5-3V	59	1.21	9.00	10.90	4-5V
23	3.13	8.00	25.00	4-3V	59	1.20	10.00	12.00	4-C
23	3.07	6.00	18.40	5-B	60	1.18	9.25	10.90	4-5V
24	2.97	6.20	18.40	5-B	60	1.18	8.50	10.00	5-C
24	2.92	6.50	19.00	5-3V	62	1.14	9.00	10.30	4-5V
25	2.88	6.40	18.40	5-B	62	1.14	10.50	12.00	4-C
25	2.80	5.00	14.00	6-3V	63	1.13	11.00	12.40	5-B
26	2.75	6.90	19.00	5-3V	63	1.12	11.80	13.20	3-5V
26	2.71	6.80	18.40	5-B	63	1.12	8.50	9.50	5-C
27	2.66	9.40	25.00	4-B	64	1.11	9.25	10.30	4-5V
27	2.64	5.30	14.00	8-3V	65	1.09	8.50	9.25	5-5V
28	2.57	6.00	15.40	6-B	65	1.09	8.60	9.40	8-B
28	2.50	5.60	14.00	6-3V	66	1.08	9.00	9.75	4-5V
29	2.48	6.20	15.40	5-B	66	1.08	12.00	13.00	4-C
29	2.41	6.40	15.40	5-B	67	1.06	11.80	12.50	3-5V
30	2.38	8.00	19.00	4-3V	67	1.06	8.50	9.00	5-C
32	2.21	5.60	12.40	6-B	68	1.05	10.00	10.50	5-C
33	2.15	6.50	14.00	5-3V	69	1.03	9.00	9.25	5-5V
33	2.14	8.60	18.40	4-B	71	1.00	10.30	10.30	4-5V
34	2.08	7.40	15.40	6-B	71	1.00	11.00	11.00	6-B
35	2.06	10.30	21.20	3-5V	73	0.97	9.25	9.00	5-5V
35	2.03	6.90	14.00	6-3V	75	0.95	11.00	10.50	5-C
35	2.02	12.40	25.00	4-B	75	0.95	10.00	9.50	5-C
36	1.97	7.10	14.00	4-5V	76	0.94	10.90	10.30	4-5V
36	1.96	9.40	18.40	5-B					
37	1.94	6.40	12.40	5-B					
38	1.88	8.50	16.00	3-5V					
38	1.86	7.00	13.00	5-C					
39	1.82	6.80	12.40	6-B					
39	1.80	11.80	21.20	3-5V					
40	1.79	8.60	15.40	5-B					
40	1.77	6.00	10.60	8-3V					
41	1.75	8.00	14.00	5-3V					
41	1.72	6.40	11.00	6-B					
43	1.67	9.00	15.00	3-5V					
43	1.67	11.00	18.40	4-B					
43	1.64	9.75	16.00	3-5V					
43	1.64	9.40	15.40	5-B					
44	1.62	9.25	15.00	4-5V					
44	1.60	7.50	12.00	5-C					
45	1.57	7.00	11.00	6-C					
46	1.56	8.00	12.50	4-5V					
47	1.51	9.25	14.00	4-5V					
47	1.50	12.00	18.00	6-A					

Every effort has been taken to ensure that the data listed in this catalogue is correct. Challenge accepts no liability for any inaccuracies or damage caused.

All dimensions in inches unless otherwise stated.

Shaft Mounted Speed Reducer

Belt Drives for 1750 rpm motors

TXT 915 Driven by 1750 rpm Motors									
Out-put rpm	V-belt Drive Ratio	Sheave Diameters		Qty. & Belt Size	Out-put rpm	V-belt Drive Ratio	Sheave Diameters		Qty. & Belt Size
		Motor	Reducer				Motor	Reducer	
16	7.04	5.40	38.00	8-B	65	1.78	9.00	16.00	6-5V
17	6.79	5.60	38.00	6-B	67	1.73	9.25	16.00	6-5V
18	6.33	6.00	38.00	6-B	68	1.71	10.50	18.00	6-C
18	6.32	5.30	33.50	6-3V	68	1.70	12.50	21.20	4-5V
19	5.98	5.60	33.50	6-3V	69	1.67	9.00	15.00	6-5V
19	5.94	6.40	38.00	5-B	69	1.67	12.00	20.00	5-C
20	5.76	6.60	38.00	5-B	71	1.64	9.75	16.00	5-5V
21	5.59	6.80	38.00	6-B	71	1.64	11.00	15.00	6-C
21	5.58	6.00	33.50	8-3V	71	1.62	9.25	15.00	6-5V
22	5.15	6.50	33.50	6-3V	72	1.61	13.20	21.20	4-5V
23	5.00	7.50	37.50	4-5V	72	1.61	12.40	20.00	10-B
23	5.00	6.00	30.00	8-B	75	1.55	10.30	16.00	5-5V
24	4.86	6.90	33.50	6-3V	75	1.54	9.75	15.00	6-5V
24	4.80	7.50	36.00	5-C	75	1.54	13.00	20.00	5-C
25	4.69	6.40	30.00	8-B	77	1.51	14.00	21.20	5-5V
26	4.41	6.80	30.00	6-B	77	1.50	12.00	18.00	6-C
27	4.29	7.00	30.00	6-C	78	1.48	12.40	18.40	10-B
28	4.19	8.00	33.50	6-3C	79	1.47	10.90	16.00	6-5V
29	4.05	7.40	30.00	8-B	81	1.43	14.00	20.00	6-C
29	3.94	7.10	28.00	5-5V	84	1.38	10.90	15.00	6-5V
31	3.75	8.00	30.00	5-C	84	1.38	13.00	18.00	6-C
31	3.73	7.50	28.00	4-5V	85	1.36	11.80	16.00	5-5V
32	3.62	6.90	25.00	3-5V	87	1.33	12.00	16.00	6-C
32	3.60	10.00	36.00	4-C	90	1.29	14.00	18.00	6-C
33	3.53	8.50	30.00	5-C	90	1.28	12.50	16.00	5-5V
33	3.50	8.00	28.00	5-5V	91	1.27	11.80	15.00	5-5V
34	3.43	10.50	36.00	4-C	96	1.21	10.90	13.20	6-5V
35	3.33	9.00	30.00	5-C	96	1.20	12.50	15.00	6-5V
35	3.29	8.50	28.00	4-5V	97	1.19	11.80	14.00	6-5V
36	3.19	9.40	30.00	6-B	102	1.14	14.00	16.00	5-5V
37	3.16	9.50	30.00	5-C	102	1.14	13.20	15.00	6-5V
37	3.13	8.00	25.00	3-5V	103	1.12	11.80	13.20	6-5V
38	3.06	12.40	38.00	5-B	107	1.08	10.90	11.80	6-5V
38	3.03	9.25	28.00	4-5V	108	1.07	14.00	15.00	5-5V
39	3.00	8.00	24.00	6-C	109	1.06	11.80	12.50	6-5V
40	2.91	8.60	25.00	6-B	109	1.06	12.50	13.20	6-5V
40	2.87	9.75	28.00	4-5V	116	1.00	11.80	11.80	6-5V
40	2.86	10.50	30.00	5-C					
41	2.84	13.20	37.50	4-5V					
42	2.73	11.00	30.00	6-B					
43	2.72	10.30	28.00	4-5V					
44	2.66	9.40	25.00	10-B					
45	2.57	10.90	28.00	4-5V					
45	2.57	14.00	36.00	4-C					
46	2.53	9.50	24.00	6-C					
48	2.40	10.00	24.00	5-C					
49	2.36	10.60	25.00	3-5V					
50	2.31	13.00	30.00	4-C					
51	2.29	9.25	21.20	5-5V					
51	2.29	10.50	24.00	5-C					
52	2.24	12.50	28.00	4-5V					
53	2.18	11.00	24.00	5-C					
53	2.17	9.75	21.20	4-5V					
54	2.13	9.40	20.00	6-B					
55	2.12	13.20	28.00	4-5V					
55	2.11	9.50	20.00	5-C					
56	2.06	10.30	21.20	4-5V					
57	2.02	12.40	25.00	6-B					
58	2.00	14.00	28.00	3-5V					
58	2.00	10.00	20.00	5-C					
60	1.94	10.90	21.20	5-5V					
61	1.90	10.50	20.00	6-C					
63	1.85	13.00	24.00	5-C					
64	1.82	11.00	20.00	6-C					
65	1.79	10.60	19.00	4-5V					

TXT 926 Driven by 1750 rpm Motors									
Out-put rpm	V-belt Drive Ratio	Sheave Diameters		Qty. & Belt Size	Out-put rpm	V-belt Drive Ratio	Sheave Diameters		Qty. & Belt Size
		Motor	Reducer				Motor	Reducer	
10	7.05	4.75	33.50	5-3V	45	1.51	9.25	14.00	5-5V
10	7.04	5.40	38.00	5-B	45	1.50	12.00	18.00	4-C
11	6.00	5.00	30.00	5-B	46	1.48	12.40	18.40	6-B
11	5.98	5.60	33.50	4-3V	46	1.47	10.90	16.00	4-5V
12	5.77	5.20	30.00	6-B	47	1.45	11.00	16.00	5-C
12	5.58	6.00	33.50	5-3V	47	1.44	9.75	14.00	4-5V
13	5.26	4.75	25.00	6-3V	48	1.43	9.25	13.20	5-5V
13	5.17	5.80	30.00	5-B	48	1.43	14.00	20.00	4-C
14	5.00	5.00	25.00	6-3V	49	1.40	11.00	15.40	6-B
14	4.81	5.20	25.00	6-B	49	1.38	14.00	19.00	5-3V
15	4.46	5.60	25.00	6-3V	50	1.37	9.50	13.00	5-C
15	4.46	5.60	25.00	6-B	50	1.36	14.00	19.00	5-3V
16	4.17	6.00	25.00	6-3V	51	1.33	12.00	16.00	4-C
16	4.17	6.00	25.00	6-B	52	1.32	10.60	14.00	6-3V
17	3.94	7.10	28.00	3-5V	52	1.32	9.40	12.40	8-B
17	3.91	6.40	25.00	5-B	53	1.29	14.00	18.00	4-C
18	3.85	6.50	25.00	5-3V	53	1.28	10.30	13.20	4-5V
18	3.79	6.60	25.00	5-B	54	1.27	11.80	15.00	4-5V
19	3.58	5.30	19.00	6-3V	54	1.26	9.50	12.00	5-C
19	3.57	5.60	20.00	6-B	55	1.24	12.40	15.40	6-B
20	3.41	5.40	18.40	6-B	56	1.21	10.30	12.50	4-5V
20	3.39	5.60	19.00	6-3V	57	1.20	10.00	12.00	5-C
21	3.19	9.40	30.00	5-B	57	1.19	11.80	14.00	4-5V
22	3.13	8.00	25.00	5-3V	58	1.18	9.25	10.90	5-5V
22	3.07	6.00	18.40	6-B	58	1.17	9.40	11.00	6-B
23	2.94	6.80	20.00	6-B	59	1.15	10.30	11.80	5-5V
23	2.92	6.50	19.00	6-3V	59	1.15	13.00	15.00	5-D
24	2.88	6.40	18.40	6-B	60	1.14	9.00	10.30	6-5V
24	2.83	7.50	21.20	4-5V	60	1.14	10.50	12.00	6-C
25	2.75	6.90	19.00	6-3V	60	1.13	11.00	12.40	8-B
25	2.71	6.80	18.40	6-B	61	1.12	12.50	14.00	4-5V
26	2.66	9.40	25.00	5-B	63	1.08	10.90	11.80	5-5V
26	2.65	8.00	21.20	4-5V	63	1.08	13.00	14.00	5-C
27	2.49	8.50	21.20	4-5V	64	1.07	13.50	14.50	5-D
27	2.49	7.40	18.40	6-B	64	1.06	10.30	10.90	5-5V
28	2.40	7.50	18.00	5-C	64	1.06	12.50	13.20	4-5V
29	2.38	8.00	19.00	6-3V	65	1.05	10.50	11.00	6-C
29	2.33	8.60	20.00	6-B	66	1.04	13.00	13.50	5-D
30	2.27	11.00	25.00	5-B	66	1.03	9.00	9.25	6-5V
30	2.25	7.10	16.00	5-5V	68	1.00	14.00	14.00	6-5V
31	2.22	9.00	20.00	4-C	68	1.00	10.50	10.50	6-C
31	2.17	9.75	21.20	3-5V	70	0.97	9.25	9.00	6-5V
32	2.14	8.60	18.40	6-B	72	0.95	11.00	10.50	6-C
32	2.13	7.50	16.00	4-5V	72	0.95	13.20	12.50	4-5V
33	2.08	7.40	15.40	3-B	72	0.95	10.50	10.00	6-C
33	2.06	10.30	21.20	4-5V	73	0.93	14.00	13.00	5-C
34	2.02	12.40	25.00	5-B	74	0.92	9.25	8.50	6-5V
34	2.00	7.50	15.00	5-5V	74	0.92	13.00	12.00	5-C
35	1.96	9.40	18.40	6-B	75	0.91	11.00	10.00	6-C
35	1.94	10.90	21.20	4-5V					
36	1.90	10.50	20.00	4-C					
36	1.88	8.50	16.00	4-5V					
38	1.79	10.60	19.00	6-3V					
38	1.79	8.60	15.40	6-B					
39	1.75	8.00	14.00	6-3V					
39	1.73	7.50	13.00	6-C					
40	1.71	10.50	18.00	4-C					
40	1.70	12.50	21.20	3-5V					
41	1.67	11.00	18.40	6-B					
42	1.64	9.75	16.00	4-5V					
42	1.64	9.40	15.40	6-B					
42	1.62	9.25	15.00	5-5V					
43	1.60	10.00	16.00	5-C					
44	1.55	10.30	16.00	4-5V					
44	1.54	13.00	20.00	4-C					

All dimensions in inches unless otherwise stated.

Every effort has been taken to ensure that the data listed in this catalogue is correct. Challenge accepts no liability for any inaccuracies or damage caused.

Shaft Mounted Speed Reducer

TXT SMSR Dimensions

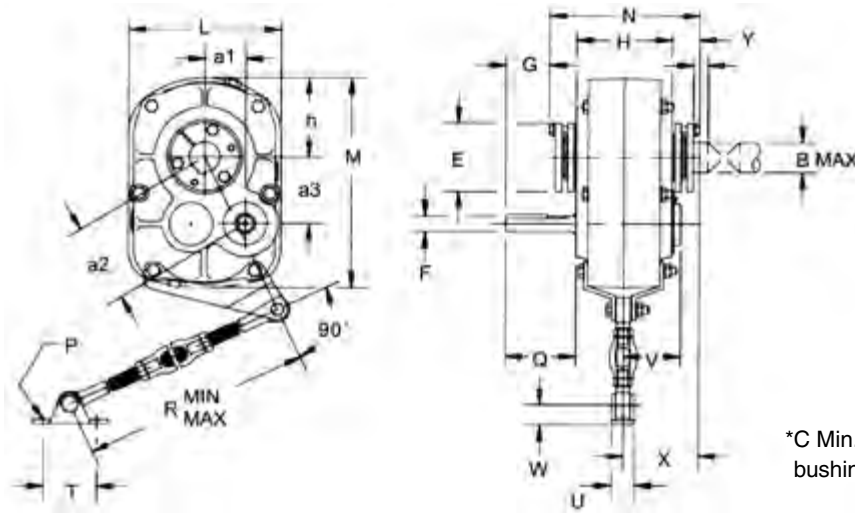

Table 5 TXT Reducer Dimensions

Size	Bmax	AGMA Size	L M	N	F Input shaft keyway	C	E G	W U	X V	Q Y	H	a1 a2	a3 h	R ^{min} R ^{max}	P T
TXT 2	1.15/16"	115	8.38 11.41	7.32	1.13 0.25 x 0.13 x 2.50	1.25	4.06 2.22	1.06 1.25	3.68 2.89	3.59 1.40	4.56	2.14 4.32	3.75 4.09	26.94 32.94	0.44 3.00
TXT 3	2.3/16"	203	9.25 12.88	9.22	1.25 0.25 x 0.13 x 2.88	1.50	4.38 2.34	1.06 1.25	4.52 3.30	4.34 1.59	5.63	2.33 4.78	4.17 4.84	26.94 32.94	0.44 3.00
TXT 4	2.7/16"	207	10.38 15.13	9.98	1.44 0.38 x 0.19 x 4.06	1.75	4.81 3.44	1.75 1.44	4.79 3.41	5.57 1.72	6.13	2.76 5.53	4.79 5.50	29.19 35.19	0.50 4.00
TXT 5	2.15/16"	215	13.13 18.31	10.52	1.94 0.5 x 0.25 x 4.50	1.81	5.63 3.44	1.75 1.44	5.05 4.45	5.74 1.91	6.31	3.04 6.43	5.67 6.56	29.19 35.19	0.50 4.00
TXT 6	3.7/16"	307	15.13 21.31	11.53	2.19 0.5 x 0.25 x 4.50	1.81	6.13 3.73	2.00 2.75	5.73 4.57	6.08 2.30	6.88	4.09 7.88	6.73 7.56	29.19 35.19	0.63 4.75
TXT 7	3.15/16"	315	18.75 25.94	12.85	2.44 0.63 x 0.31 x 4.75	2.06	7.25 3.75	2.00 2.75	6.38 4.69	6.35 2.50	7.75	5.11 9.74	8.30 9.38	29.44 35.44	0.63 4.75
TXT 8	4.7/16"	407	20.25 28.25	14.03	2.44 0.63 x 0.31 x 5.38	2.06	7.75 4.31	3.13 4.00	7.04 5.85	7.11 2.86	8.37	6.03 11.25	9.50 10.13	30.00 36.00	0.75 7.00
TXT 9	4.15/16"	415	22.63 31.69	14.12	2.44 0.63 x 0.31 x 7.75	2.44	8.75 6.63	3.13 4.00	7.04 5.66	9.65 2.98	8.12	6.59 12.66	10.81 11.31	30.00 36.00	0.75 7.00

TXT Shaft Mounted Reducers can be provided for metric input shafts and output straight bore hubs according to ISO standards.

Table 6 Metric input Shaft and Output Straight Bore Hub (mm)

Size	TXT 2	TXT 3	TXT 4	TXT 5	TXT 6	TXT 7	TXT 8	TXT 9
Input Shaft F(h6)	28	30	35	48	55	60	60	60
Output Bore Hub B(F7)	45	55	60	75	85	100	110	125

Shaft Mounted Speed Reducer

Table 7 TXT Output Hub Bushings

Note, taper bushed reducers require bushing for all bore sizes.

Size	Bore Size	Shaft Keyseat Required	Weight (lb.)	Size	Bore Size	Shaft Keyseat Required	Weight (lb.)	
TXT 215 & 225	1-1/8	1/4 x 1/8 x 6-11/16	3.8	TXT 515 & 525	2	1/2 x 1/4 x 9-3/8	10.2	
	1-3/16	1/4 x 1/8 x 6-11/16	3.6		2-3/16	1/2 x 1/4 x 9-3/8	10	
	1-1/4	1/4 x 1/8 x 6-11/16	3.6		2-1/4	1/2 x 1/4 x 9-3/8	9.2	
	1-5/16	5/16 x 5/32 x 6-11/16	3.6		2-7/16	5/8 x 5/16 x 9-3/8	8.5	
	1-3/8	5/16 x 5/32 x 6-11/16	3.6		2-1/2	5/8 x 5/16 x 9-3/8	8.5	
	1-7/16	3/8 x 3/16 x 6-11/16	4		2-11/16	5/8 x 5/16 x 9-3/8	7.9	
	1-1/2	3/8 x 3/16 x 6-11/16	3.8		2-15/16	3/4 x 3/8 x 9-3/8	7.8	
	1-5/8	3/8 x 3/16 x 6-11/16	3.2		TXT 615 & 625	2-3/16	1/2 x 1/4 x 10-11/16	15.3
	1-1/16	3/8 x 3/16 x 6-11/16	3.4			2-1/4	1/2 x 1/4 x 10-11/16	14.9
	1-3/4	3/8 x 3/16 x 6-11/16	3.3			2-7/16	5/8 x 5/16 x 10-11/16	14.4
	1-15/16	1/2 x 1/4 x 6-11/16	2.9			2-1/2	5/8 x 5/16 x 10-11/16	14
	TXT 315 & 325	1-5/16	5/16 x 5/32 x 8-1/16			5.8	2-11/16	5/8 x 5/16 x 10-11/16
1-3/8		5/16 x 5/32 x 8-1/16	5.8	2-7/8		3/4 x 3/8 x 10-11/16	12.2	
1-7/16		3/8 x 3/16 x 8-1/16	5.6	2-15/16		3/4 x 3/8 x 10-11/16	11.6	
1-1/2		3/8 x 3/16 x 8-1/16	5.4	3		3/4 x 3/8 x 10-11/16	11.3	
1-5/8		3/8 x 3/16 x 8-1/16	4.8	3-7/16		7/8 x 7/16 x 10-11/16	9	
1-11/16		3/8 x 3/16 x 8-1/16	4.8	TXT 715 & 725		2-7/16	5/8 x 5/16 x 11-27/32	24.2
1-3/4		3/8 x 3/16 x 8-1/16	4.8			2-1/2	5/8 x 5/16 x 11-27/32	23.3
1-7/8		1/2 x 1/4 x 8-1/16	4.3			2-11/16	5/8 x 5/16 x 11-27/32	23
1-15/16		1/2 x 1/4 x 8-1/16	4.4		2-13/16	3/4 x 3/8 x 11-27/32	22.8	
2		1/2 x 1/4 x 8-1/16	4.1		2-7/8	3/4 x 3/8 x 11-27/32	21.5	
2-3/16		1/2 x 1/4 x 8-1/16	3.7		2-15/16	3/4 x 3/8 x 11-27/32	21.3	
TXT 415 & 425		1-7/16	3/8 x 3/16 x 9-1/32		8.8	3	3/4 x 3/8 x 11-27/32	20.1
	1-1/2	3/8 x 3/16 x 9-1/32	8.3		3-3/16	3/4 x 3/8 x 11-27/32	19.2	
	1-5/8	3/8 x 3/16 x 9-1/32	8.3		3-7/16	7/8 x 7/16 x 11-27/32	16.9	
	1-11/16	3/8 x 3/16 x 9-1/32	8.3		3-15/16	1 x 1/2 x 11-27/32	13.8	
	1-3/4	3/8 x 3/16 x 9-1/32	8		TXT 815 & 825	2-15/16	3/4 x 3/8 x 13-1/16	29
	1-7/8	1/2 x 1/4 x 9-1/32	8			3-3/16	3/4 x 3/8 x 13-1/16	25.8
	1-15/16	1/2 x 1/4 x 9-1/32	7.4	3-7/16		7/8 x 7/16 x 13-1/16	25	
	2	1/2 x 1/4 x 9-1/32	7.1	3-15/16		1 x 1/2 x 13-1/16	20	
	2-1/8	1/2 x 1/4 x 9-1/32	7	4-3/16		1 x 1/2 x 13-1/16	17	
	2-3/16	1/2 x 1/4 x 9-1/32	6.7	4-7/16		1 x 1/2 x 13-1/16	15	
	2-1/4	1/2 x 1/4 x 9-1/32	6.3	TXT 915 & 926		3-7/16	7/8 x 7/16 x 12-15/16	36
	2-7/16	5/8 x 5/16 x 9-1/32	5.8			3-15/16	1 x 1/2 x 12-15/16	32.4
TXT 515 & 525	1-7/8	1/2 x 1/4 x 9-3/8	10.3			4-7/16	1 x 1/2 x 12-15/16	27
	1-15/16	1/2 x 1/4 x 9-3/8	10.3			4-15/16	1-1/4 x 5/8 x 12-15/16	22

Note: All the above bushings are standard. When ordering the reducer, please determine the output bushing's bore diameter. The shaft key is also supplied. Check the driven shaft and key for strength.

Shaft Mounted Speed Reducer

TXT SMSR Installation

Satisfactory performance depends on correct installation, lubrication and maintenance. Therefore it is important that the instructions in this manual are followed carefully.

1. Use eyebolts or lifting lugs to lift reducer.
2. Determine the running positions of the reducer. (See Fig. 1) Note that the reducer supplied with 4 plugs around the sides. These plugs must be arranged relative to the running positions as follows: the bottom one is drain plug, please replace this plug with a magnetic plug. Throw away the tape that covers the filter plug in shipment and install it in topmost hole. For the 2 remaining plugs on the sides of the reducer, the lowest one is the minimum oil level plug.

The running position of the reducer is not limited to the four positions shown in Fig. 1. However, if the running position is over 20° in position “B” & “D” or 5° in position “A” or “C”, either way from sketches, the oil level plug cannot be used safely to check the oil level, unless during the checking, the torque arm is disconnected and the reducer is swung to within 20° for position “A” & “C” or 5° for position “B” & “D” of the positions shown in Fig. 1. Because of the many possible positions of the reducer, it may be necessary or desirable to make special adaptations using the lubrication filling holes furnished along with other standard pipe fittings, stand pipes and oil level gauges as required.

Fig. 1 - Mounting Positions

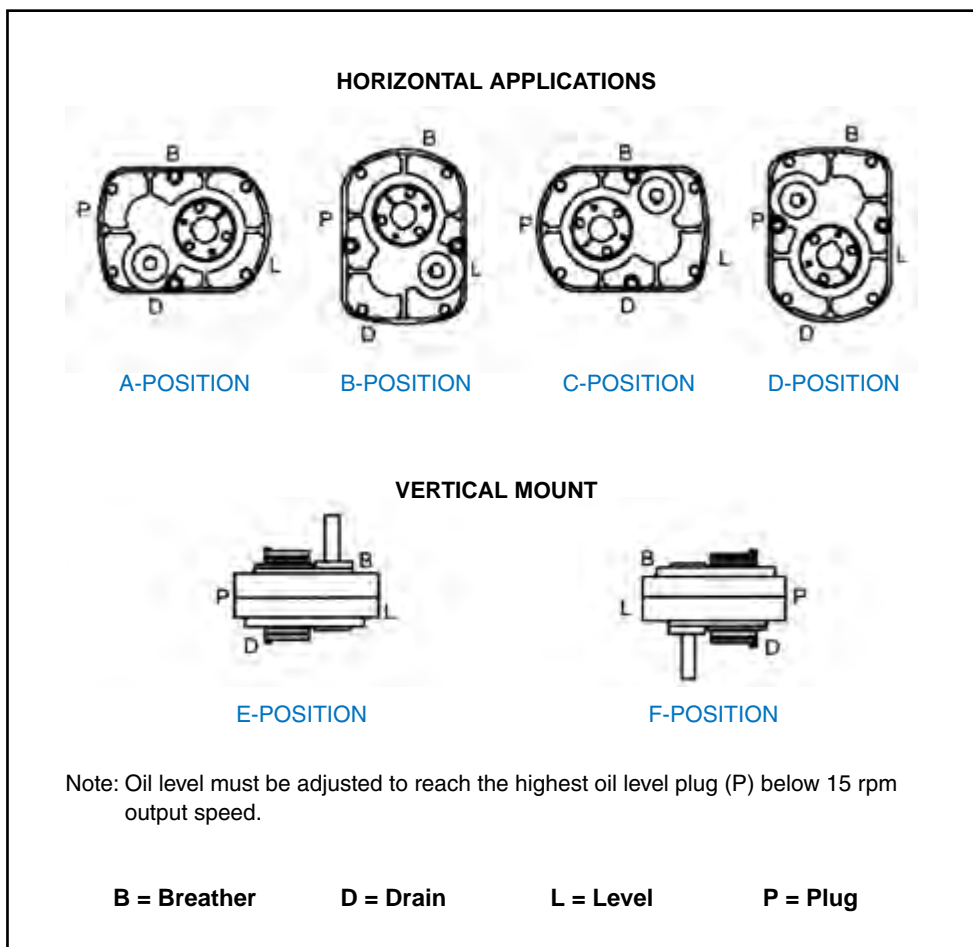

Shaft Mounted Speed Reducer

TXT SMSR Installation (continued)

3. Mount reducer on driven shaft as follows:

To ensure that the drive is not unexpectedly started, turn off lock out or tag power source before proceeding. Failure to observe these precautions could result in bodily injury.

- (1) Install sheave on gearbox input shaft as close to the reducer as possible, and mount reducer on driven shaft as close to the bearing as is practical (keep minimum distance sufficient for removal of bushing screws, see Fig.2). Failure to do this will cause excess loads in the input shaft bearings and output bearings and could cause their premature failure.
- (2) Install motor and belt drive with the belt pull at approximately 90° to the center line between driven and input shafts (see Fig.3). This will permit tensioning of the belt drive with the torque arm which should preferably be in tension. If the output hub runs anti-clockwise, the torque arm should be positioned to the right (see Fig.4).
- (3) Install torque-arm fulcrum on a rigid support so that the torque arm will be at approximately right angles to the center line through the driven shaft and the torque arm case bolt (see Fig.5). Make sure there is sufficient take up in the turnbuckle for belt tension adjustment.

Fig. 2

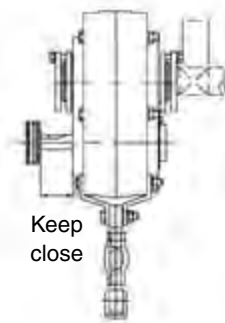

Keep close to driven machine, but keep distance sufficient for removal of bushing screws.

Fig. 3



Belt drive may be located to the right if desired

Belt drive may be located in any convenient position. If the torque arm is to be used to tighten the belts, the drive should be at about 90° to line between the input and output shafts

Fig. 4



If output hub rotates clock-wise, installation direction is opposite of the drawing shown.

Fig. 5

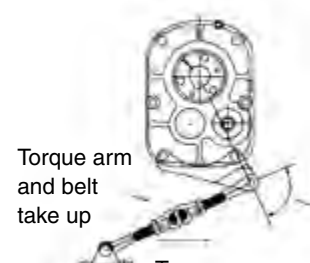

Torque arm and belt take up

Torque arm may be positioned to the right if desired.

This angle should be a right angle, but may vary upto a maximum of 30° either way.

Shaft Mounted Speed Reducer

Lubrication

IMPORTANT: Because Shaft Mounted Reducers are dispatched without oil. It is necessary to fill the gearbox with the correct amount of oil before running. Use a high-grade petroleum base rust and oxidation inhibited (R&O) gear oil. Follow instructions on reducer warning tags, and in the installation manual.

After the first 100 hours running, drain reducer and flush with kerosene, clean the drain plug and refill to proper level with new lubricant. Under average industrial operating conditions, the lubricant should be changed every 2500 hours of operating or every 6 months.

CAUTION: Extreme pressure (EP) lubricants are not recommended for average operating conditions. Failure to observe this precaution could result in bodily injury.

CAUTION: Too much oil will cause overheating and too little will result in gear failure. Check oil level regularly. Failure to observe this precaution could result in bodily injury.

Under extreme operating conditions, such as rapid rise and fall of temperature, dust, dirt, chemical particles, chemical fumes, or oil sump temperature above 200°F, the oil should be changed every 1 to 3 months, depending on severity of conditions.

CAUTION: Do not use EP oils containing slippery additives such as graphite or molybdenum disulfide in the reducer when backstop is used. These additives will destroy sprag action.

Table 8 Oil Quantities (Approximate Capacity in Quarts)

Mounting Position	Size							
	TXT 2	TXT 3	TXT 4	TXT 5	TXT 6	TXT 7	TXT 8	TXT 9
A	0.875	1.5	1.875	3.25	4.25	6.5	8.5	13
B	1	1.5	2.25	4	5	8	11	13
C	0.625	0.75	1.25	3.25	4.25	7.25	10.5	12.5
D	1	2.25	1.75	4	5	9.25	8.5	14.25
E	1.625	2.625	3.375	7	8.625	15.375	19.125	25.375
F	1.75	3	4.25	8.625	9.125	16.375	19.125	25.375

Note: Mounting position refer to Figure 1 on page 397.

If reducer position is to vary from those show in Figure 1, either more or less oil may be required, consult Challenge.

If output is less than 15rpm, the oil level must be adjusted to reach the highest oil level plug (P).

If the mounting position is "B" or "D" and backstop is used, consult Challenge for the correct oil level.

Table 9 Mineral oil (TXT2 to TXT9)

	Environment Temperature		15:1 and 25:1 Ratio Gearboxes		
	°C	°F	0-20 rpm	21-50 rpm	51-120 rpm
ISO Viscosity Grade	-10°C to +5°C	14°F to 40°F	150	150	100
	6°C to 25°C	43°F to 77°F	680	460	320
	26°C to 40°C	79°F to 104°F	800	800	460

Table 10 Manufactures and Types

B.P. ENERGOL GR-XP	CASTROL ALPHA ZN OR SP	MOBIL MOBILGEAR OIL	SHELL OMALA	TEXACO MEROPE	DARMEX 9140 NMNND	Suitable for all ambient temperatures and all input speeds
--------------------------	------------------------------	---------------------------	----------------	------------------	----------------------	--

Note: Do not use E.P. mineral oils other than those recommended when using a backstop.

Shaft Mounted Speed Reducer

Table 11 Maximum input speeds, driven speeds, actual ratio and weights for TXT reducers.

Size	Nominal Ratio 15:1			Nominal Ratio 25:1			Weight lbs
	Actual Ratio	Maximum Input rpm	Maximum Output rpm	Actual Ratio	Maximum Input rpm	Maximum Output rpm	
TXT 2	14.04	1974	140	23.37	1994	85	58
TXT 3	14.87	2083	140	24.75	2100	85	98
TXT 4	15.13	2118	140	24.38	2072	85	139
TXT 5	15.40	1925	125	25.56	2044	80	207
TXT 6	15.34	1916	125	25.14	2010	80	285
TXT 7	15.23	1827	120	24.84	1863	75	462
TXT 8	15.08	1809	120	24.62	1847	75	633
TXT 9	15.12	1814	120	25.66	1925	75	760

Table 12 TXT reducer's output shaft overhung load ratings

Size	Shaft Size	Overhung Load (lbs) at Various RPM's										
		10	20	30	50	80	100	120	140	160	180	200
TXT 2	1-7/16	2000	1510	1270	1010	840	820	720	720	710	710	700
	1-15/16	1750	1320	1110	890	730	710	630	630	620	620	610
TXT 3	1-15/16	5400	4250	3680	3050	2620	2440	2310	2210	2110	2040	1980
	2-3/16	5240	5120	3570	2960	2540	2370	2240	2140	2050	1980	1920
TXT 4	2-3/16	6520	5180	4510	3800	3230	3000	2830	2710	2600	2510	2430
	2-7/16	6360	5060	4410	3710	3160	2930	2770	2640	2530	2450	2370
TXT 5	2-7/16	7460	5860	5080	4280	3690	3450	3270	3110	2980	2880	2790
	2-15/16	7060	5540	4800	4040	3490	3260	3090	2940	2820	2720	2640
TXT 6	2-15/16	9100	7100	6100	5000	4100	4050	3700	3550	3400	3300	3200
	3-7/16	8200	6400	5500	4500	3700	3650	3400	3300	3250	3200	3150
TXT 7	3-7/16	11400	9500	7300	5950	4750	5050	4500	4300	4250	4200	4150

Table 13 NEMA Motor Information (1750rpm)

Horse Power	NEMA Motor Frame	Shaft Diameter	Minimum Sheave Diameter
1	143T	7/8	2.2
1-1/2	145T	7/8	2.4
2	145T	7/8	2.4
3	182T	1-1/8	2.4
5	184T	1-1/8	3.0
7-1/2	213T	1-3/8	3.0
10	215T	1-3/8	3.8
15	254T	1-5/8	4.4
20	256T	1-5/8	4.4
25	284T	1-7/8	4.4
30	286T	1-7/8	5.2
40	324T	2-1/8	6.0
50	326T	2-1/8	6.8
60	364T	2-3/8	7.4
75	365T	2-3/8	8.6
100	405T	2-7/8	8.6
125	444T	3-3/8	10.5
150	445T	3-3/8	10.5
200	447T	3-3/8	13.2

Table 14 Minimum Sheave Diameters for TXT Reducers

Reducer Size	Shaft Diameter	Minimum Sheave Diameter
TXT 2	1-1/8	3.0
TXT 3	1-1/4	4.0
TXT 4	1-7/16	4.6
TXT 5	1-15/16	5.4
TXT 6	2-3/16	6.2
TXT 7	2-7/16	6.2
TXT 8	2-7/16	6.2
TXT 9	2-7/16	8.0

All dimensions in inches unless otherwise stated.

Every effort has been taken to ensure that the data listed in this catalogue is correct. Challenge accepts no liability for any inaccuracies or damage caused.

Shaft Mounted Speed Reducer

Exploded view of a TXT reducer

When ordering parts for reducer, please specify

- | | |
|--------------------------|----------------------|
| 1. Reducer Size Number | 4. Part Name |
| 2. Reducer Ratio | 5. Code Number |
| 3. Reducer Serial Number | 6. Quantity Required |

No.	Part Name
1	Right hand gear case
2	Output hub bearing
3	Output hub
4	2nd reduction gear key
5	1st reduction gear key
6	Intermediate pinion
7	2nd reduction gear
8	Oil pipe plug
9	Left hand gear case
10	Breather plug
11	Output hub bearing cover gasket
12	Output hub bearing cover
13	Output hub oilseal
14	Cover lock washer
15	Cover bolt
16	Case bolt
17	Hollow dowel
18	Output hub collar
19	Output hub circlip
20	Case plain washer
21	Lifting eye

No.	Part Name
22	Input shaft oilseal
23	Input shaft bearing cover
24	Bearing cover gasket
25	Intermediate bearing cover
26	Bearing cover gasket
27	Intermediate pinion bearing (input side)
28	Input shaft bearing (input side)
29	Input shaft square key
30	Input shaft & pinion
31	1st reduction gear
32	Input shaft bearing (output side)
33	Intermediate pinion bearing (output side)
34	Backstop cover gasket
35	Backstop cover
36	Intermediate cover gasket
37	Intermediate pinion cover
38	Cross recessed screw
39	Case nut
40	Case lock washer
41	Adaptor for torque arm (not shown)
42	Torque arm (not shown)

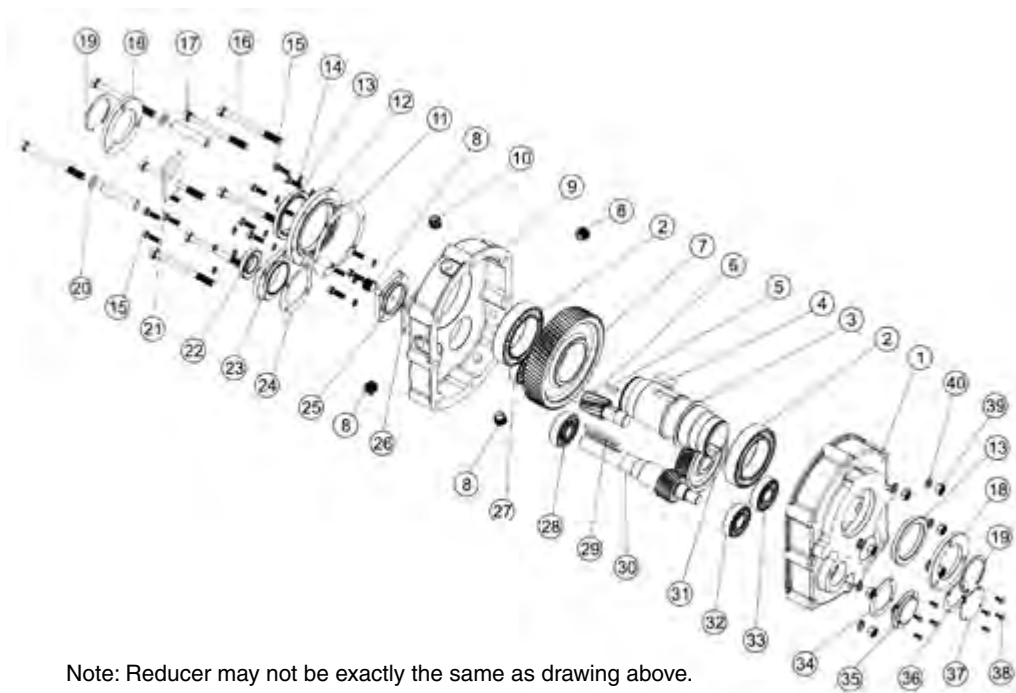

Note: Reducer may not be exactly the same as drawing above.
Spare parts may vary for each reducer.

Challenge Group Companies

AUSTRALIA

Challenge Power Transmission (Aust) Pty Ltd
B11, Scoresby Industry Park
Janine Street
Scoresby
Victoria 3179
Australia
Tel: (03) 9763 6701 Fax: (03) 9764 0890
Email: aussales@challengept.com

CZECH REPUBLIC

Challenge PT (Czech) s.r.o.
Hulínská 1799, areál Magneton
767 01 Kroměříž
Česká Republika
Tel: +420 573 334 106 Fax: +420 573 330 556
Email: czsales@challengept.com

GERMANY

Challenge Power Transmission GmbH
In der Neuwies 1
D-35745 Herborn
Germany
Tel: +49 2772 575860 Fax: +49 2772 5758620
Email: desales@challengept.com

IRELAND

Challenge Power Transmission (Ireland) Ltd
Unit 202
Holly Road
Western Industrial Estate
Dublin 12
Eire
Tel: +353 1 4566311 Fax: +353 1 4566312
Email: ireland@challengept.com

CHINA (Shijiazhuang)

Challenge Power Transmission (SHZ) Plc
South of Daxizhang
High Technology Developing Area
Shijiazhuang 050035
China
Tel: +86 311-85385510 Fax: +86 311 8538 5590
Email: cnsales@challengept.com

SOUTH AFRICA

Challenge Power Transmission Africa (Pty) Ltd
Cnr Estee Ackermann and Yaldwyn Streets
Jet Park, Boksburg
Gauteng, Johannesburg
1459
South Africa
Tel: +27 11 3976115 Fax: + 27 11 3978494
Email: sasales@challengept.com

UNITED KINGDOM

Challenge Power Transmission Ltd
Merryhills Enterprise Park
Park Lane
Wolverhampton
WV10 9TJ
United Kingdom
Tel: +44 1902 866116 Fax: +44 1902 866117
Email: uk@challengept.com

CHINA (Ningbo)

Challenge Power Transmission (Ningbo) Ltd
Bao Zhan Avenue, Xiao Bai Village,
Dong Wu Town, Yin Zhou District, Ningbo City,
Zhejiang Province, China
Tel: +86 574 8833 4378 Fax: +86 574 8833 4379
Email: ningbo.sales@challengeproduction.com

CHALLENGE GROUP OF COMPANIES TERMS OF SALE

These Terms do not apply if you deal as a Consumer Your statutory rights are not affected by these conditions

1. DEFINITIONS

In these Terms of Sale the following meanings shall apply:

"We" and "Us"	means	CHALLENGE WORLDWIDE Plc
"You"	means	the person seeking to purchase Goods from Us.
"the Goods"	means	the goods or where the context permits the services to be supplied by Us.
"Company Signatory"	means	a person authorised by Us.
"the Terms"	means	the terms set out in this document and special terms agreed in writing between a Company Signatory and You or on Buyer's order.
"the Contract"	means	the contract for the supply of Goods incorporating these Terms.
"Consumer"	means	any natural person acting for purposes outside their trade, business or profession.
"the Defect"	means	the condition and/or any attribute of the Goods and/or any other circumstances which but for the effect of these Terms would have entitled You to damages.

2. THE CONTRACT

- All orders are accepted by Us only under these Terms and they may not be altered other than with the written agreement of a Company Signatory. Any contrary or additional terms unless so agreed are excluded.
- Quotations are invitations to treat only.
- Orders may be cancelled only with the written agreement of a Company Signatory and You will indemnify Us against all costs claims losses or expenses incurred as a result of that cancellation.
- You shall be responsible to Us for ensuring the accuracy of the terms of any order including any applicable design drawing or specification provided to Us by You and for giving Us any necessary information relating to the Goods within a sufficient time to enable Us to perform the Contract in accordance with its Terms.
- It is Your responsibility to be fully conversant with the nature and performance of the Goods, including any harmful effects their use may have.
- Without prejudice to Clause 2.5.4 of these Terms while We take every precaution in the preparation of our catalogues technical circulars price lists and other literature these documents are for your general guidance only and statements included in these documents (in the absence of fraud on our part) shall not constitute representations by Us and We shall not be bound by them.
- We undertake to comply with the Safety Legislation including, but not limited to the provision of any available information relating to the safety of the Goods to secure so far as reasonable practicable the health and safety of the users of the Goods.
- You will comply with the Safety Legislation and agrees to indemnify and keep indemnified Us against Your failure to comply with the Safety Legislation. In particular, You shall indemnify Us against any and all claims or proceedings resulting from any injury, loss or damage caused by a failure to use the Goods in accordance with Our instructions whether such failure is on the part of the Your employees, contractors or agents or a third party to whom You have supplied the Goods.
- We shall not be liable in respect of any misrepresentation made by Us our employees or agents to You our employees or agents as to the condition of the Goods their fitness for any purpose or as to quantity or measurements unless the representation is:
 - made or confirmed in writing by a Company Signatory; and/or
 - fraudulent
- For the avoidance of doubt our liability for damages for misrepresentation (other than fraudulent) is excluded or limited by Clause 8 of these Terms.

3. PRICE

- The price of the Goods shall be as published in our price list current at the date of delivery of the Goods. The price is exclusive of VAT which shall be due at the rate ruling on the date of a VAT invoice.
- Prices listed or quoted are based on costs prevailing at the time when they are given or agreed. We shall be entitled to adjust the price of the Goods as at the time of delivery by such amount as may be necessary to cover any increase sustained by Us after the date of acceptance of your order and any direct or indirect costs of making obtaining handling or supplying the Goods.
- Prices listed or quoted are applicable to the quantity specified and on the information provided by You at the time of order. In the event of orders being placed for lesser quantities or if there is any change in specifications, delivery dates, or delay is caused by our instructions or lack of instructions we shall be entitled to adjust the price of the Goods as ordered to take account of the variations.
- We shall have the option of supplying any Goods ordered by You in imperial measurements in the nearest equivalent metric measurements and the Goods may be charged in metric measure allowing for conversions.

4. PAYMENT

- Unless other credit terms have been agreed in writing with a Company Signatory all accounts are due for payment on the last day of the month following the month in which the Goods are delivered.
- Late payments will incur interest at the rate of 5% per annum above the base rate of Barclays Bank Plc in force from time to time from the due date until the date of payment after as well as before judgement.
- Credit facilities may be withdrawn or reduced at any time in our sole discretion.
- Even if We have previously agreed to give You credit we reserve the right to refuse to execute any order or contract if the arrangements for payment or your credit rating is not satisfactory to Us. In our discretion We may require security satisfactory to Us or payment for each consignment when it is available and before it is despatched in which case delivery will not be effected until We are in receipt of security or cleared funds as requested by Us.
- In the case of short delivery You will remain liable to pay the full invoice price of all goods delivered or available for delivery.
- You may not withhold payment of any invoice or other amount due to Us by reason of any right of set off or counterclaim which You may have or allege to have for any reason whatever.
- We shall be entitled at all times to set off any debt or claim of whatever nature which We may have against You against any sums due from Us to You.

5. DELIVERY

- Delivery will be effected when the Goods leave our premises whether carried by Us or an independent carrier or the premises of our suppliers when the Goods are delivered direct from suppliers.
- Delivery dates are given in good faith but are estimates only.
- Time for delivery shall not be of the essence of the Contract.
- For the avoidance of doubt and without detracting from any other provisions of these Terms We shall not be liable for any damages whatsoever whether direct or indirect (including for the avoidance of doubt any liability to any third party) resulting from any delay in delivery of the Goods or failure to deliver the Goods in a reasonable time whether such delay or failure is caused by our negligence or otherwise howsoever.
- We reserve the right to make delivery by instalments and tender a separate invoice in respect of each instalment. Our failure to deliver any one or more instalments or any claim by You in respect of any one or more instalments shall not entitle You to treat the Contract as a whole as repudiated.
- The price agreed includes our normal delivery charges but We may make an additional charge if We incur further costs or expense such as (but not limited to) those caused by delivery of less than a full load; complying with your request for delivery outside our normal delivery pattern or trading hours; or by instalments; orders of small value which are not economical for us to deliver free.
- You must provide the necessary labour for unloading the Goods and unloading is to be completed with reasonable speed. If our delivery vehicle is kept waiting for an unreasonable time or is obliged to return without completing delivery or if We provide additional staff to unload Goods an additional charge will be made.
- You may collect Goods from Us during our trading hours. If they are not collected within 14 days from when We notify You that they are available a storage charge will be payable before the Goods are released.
- If you fail to take delivery accept or collect the Goods within the agreed time in our discretion We may make an additional charge, invoice You for the Goods or treat the contract as repudiated and in any case recover our losses from You.
- If You collect Goods from Us You are solely responsible for the size weight and positioning of the load on the vehicle and shall indemnify Us in respect of all costs claims losses or expenses We may incur as a result of your collecting the Goods including any resulting from our negligence.

6. INSPECTION

- You shall inspect the Goods at the place and time of unloading or collection but nothing in these Terms shall require You to break packaging and/or unpack Goods which are intended to be stored before use.
- You must advise Us by telephone immediately and give Us written notice within three working days of unloading of any claim for short delivery.
- If You do not give Us that notice within that time the Goods will be deemed to have been delivered in the quantities shown in the delivery documents.
- You shall not be entitled and irrevocably and unconditionally waive any right to reject the Goods or claim any damages whatsoever for short delivery howsoever caused.
- Our liability for short delivery is limited to make good the shortage.
- Where it is or would have been apparent on a reasonable inspection that the goods are not in conformity with the Contract or (where the Contract is a contract for sale by sample) that the bulk does not compare with the sample You must advise Us by telephone immediately and give us written notice within three working days of inspection.
- If you fail to give Us that notice within that time the Goods will be deemed to have been accepted and You shall not be entitled and irrevocably and unconditionally waive any right to reject the Goods.
- If you fail to give Us that notice within that time Clause 8 shall have effect.

7. TITLE AND RISK

- Risk in the Goods shall pass to You when the Goods are delivered.
- The property in the Goods shall remain with Us until You pay all sums due to Us whether in respect of this Contract or otherwise.
- Until title passes:-
 - You shall hold the Goods as our fiduciary agent and bailee.
 - The Goods shall be stored separately from any other goods and You shall not interfere with any identification marks labels batch numbers or serial numbers on the Goods.
 - We agree that You may use or agree to use the Goods as principal and not as our agents in the ordinary course of your business subject to the express condition that at our direction the entire proceeds of any sale or insurance proceeds received in respect of the goods are held in trust for Us and not mixed with any other monies or paid into an overdraft bank account and shall at all times be identifiable as our money.
- We shall be entitled at any time to recover any or all of the Goods in your possession to which We have title and for that purpose We our employees or agents may with such transport as is necessary enter upon any premises occupied by You or to which You have access and where the Goods may be or are believed to be situated.

8. LIABILITIES

- Nothing in these Terms shall exclude or restrict our liability for death or personal injury resulting from our negligence or our liability for fraudulent misrepresentation.
- Subject to Clause 8.1 these Terms shall not be liable by reason of any misrepresentation (unless fraudulent) or any breach of warranty condition or other term express or implied or any breach of duty (common law or statutory) or negligence for any damages whatsoever. Instead of liability in damages We undertake liability under Clause 8.3 below.
- Where but for the effect of Clause 8.2 of these Terms You would have been entitled to damages against Us We shall not be liable to pay damages but subject to the conditions set out in Clause 8.4 below shall in our sole discretion either repair the Goods at our own expense or supply replacement Goods free of charge or refund all (or where appropriate part) of the price paid for the relevant Goods.
- We will not be liable under Clause 8.3:
 - If the Defect arises from fair wear and tear.
 - If the Defect arises from wilful damage negligence abnormal working conditions mis-use alteration or repair of the Goods failure to follow British Standard or industry instructions relevant to the

Goods or storage of the Goods in unsuitable conditions (but this sub-clause shall not apply to any act or omission on our part)

- Unless after discovery of the Defect we are given a reasonable opportunity to inspect the Goods before they are used or in any way interfered with. For the avoidance of doubt We acknowledge that the costs of suspending works are relevant to the determination of what is a reasonable opportunity and this sub-clause shall not apply to any works affecting the Goods which it may be reasonably necessary to carry out in the interests of safety and/or as emergency measures.
- If the Defect would have been apparent on a reasonable inspection under Clause 6.1 of these Terms at the time of unloading unless You advise Us by telephone immediately and written notice of any claim is given to Us within three working days of the time of unloading; or in any other case.
- The Defect is discovered within four months from the date of delivery and We are given written notice of the Defect within three working days of it being discovered.
- If the Goods are manufactured processed or milled by Us to the design quantity measure or specification of You or your agents then;
 - Subject to Clause 8.1 of these Terms We shall not be under any liability for damages whatsoever or under Clause 8.3 of these Terms as the case may be except in the event of:
 - Fraudulent misrepresentation.
 - Misrepresentation where the representation was made or confirmed in writing by a Company Signatory.
 - Non-compliance with such design quantity measurement or specification.
 - Breach of a written warranty signed by a Company Signatory that the Goods are fit for that purpose; or
 - Claim maintainable against Us pursuant to Clause 8.1 of these Terms.
- You will unconditionally fully and effectively indemnify Us against all loss damages costs on an indemnity basis and expenses awarded against or incurred by Us in connection with or paid or agreed to be paid by Us in settlement of any claim for infringement of any patents copyright design trademark or any other industrial or intellectual property rights of any other person.
- You will further unconditionally fully and effectively indemnify Us against all loss damages costs on an indemnity basis and expenses awarded against or incurred by Us in connection with or paid or agreed to be paid by Us in settlement of any other claim arising from any such manufacturing processing or milling including but not limited to any Defect in the Goods. This indemnity will be reduced in proportion to the extent that such loss damage costs and expenses are due to our negligence.
- You will unconditionally fully and effectively indemnify Us against all loss damages costs on an indemnity basis and expenses awarded against or incurred by Us in connection with or paid or agreed to be paid by Us in settlement of any claim by any third party arising from the supply or use of the Goods. This indemnity will be reduced in proportion to the extent that such loss damage costs and expenses are due to our negligence.
- Without prejudice to any other provisions in these Terms in any event our total liability for any one claim or for the total of all claims arising from any one act of default on our part (whether arising from our negligence or otherwise) shall not exceed the purpose price of the goods the subject matter of any claim.

9. NON PAYMENT/INSOLVENCY

- "Insolvent" means You becoming unable to pay your debts within the meaning of Section 123 of the Insolvency Act 1986; the levying or the threat of execution or distress on any of your property; the appointment of a receiver or administrative receiver over all or any part of your property; a proposal for a voluntary arrangement or compromise between You and your creditors whether pursuant to the Insolvency Act 1986 or otherwise; the passing of a resolution for voluntary winding-up or summoning a meeting to pass such a resolution otherwise than for the purposes of a bona fide amalgamation or reconstruction; the presentation of a petition for your winding-up or for an administration order in relation to You; if You suffer any analogous step or proceedings under foreign law or You ceasing or threatening to cease to carry on your business.
- If you fail to pay the price for any Goods on the due date or fail to pay any sum due to Us under any contract on the due date or You become insolvent or if You are a Limited Company or partnership and there is a material change in your constitution or You commit a material breach of this Contract and fail to remedy that breach all sums outstanding between You and Us shall become immediately payable and We shall be entitled to do any one or more of the following (without prejudice to any other right or remedy We may have)
 - Require payment in cleared funds in advance of further deliveries.
 - Cancel or suspend any further deliveries to You under any contract without liability on our part.
 - Without prejudice to the generality of Clause 7 of these Terms exercise any of our rights pursuant to that clause.
 - If we reasonably incur third party costs such as tracing or debt collection agency costs or seek legal advice or take legal proceedings to enforce our rights as a result of your breach of this Contract including but not limited to recovery of any sums due, you will reimburse us such reasonable agency costs or legal costs incurred on an indemnity basis.
- GENERAL
 - This Contract shall be governed and interpreted according to the law of England and Wales and You agree to submit to the non-exclusive jurisdiction of the English Courts.
 - We shall not be liable for any delay or failure to perform any of our obligations in relation to the Goods due to any cause beyond our reasonable control including industrial action.
 - The waiver by Us of any breach or default of these Terms shall not be construed as a continued waiver of that breach nor as a waiver of any subsequent breach of the same or any other provision.
 - If any clause or sub-clause of these Terms is held by a competent authority to be invalid or unenforceable the validity of the other clauses and sub-clauses of these Terms shall not be affected and they shall remain in full force and effect.
 - We may assign novate or sub-contract all or part of this Contract and You shall be deemed to consent to any novation. This Contract is personal to You and it may not be assigned.
 - Nothing in this Contract is intended to or will grant any right to any third party to enforce any terms of this contract whether express or implied.

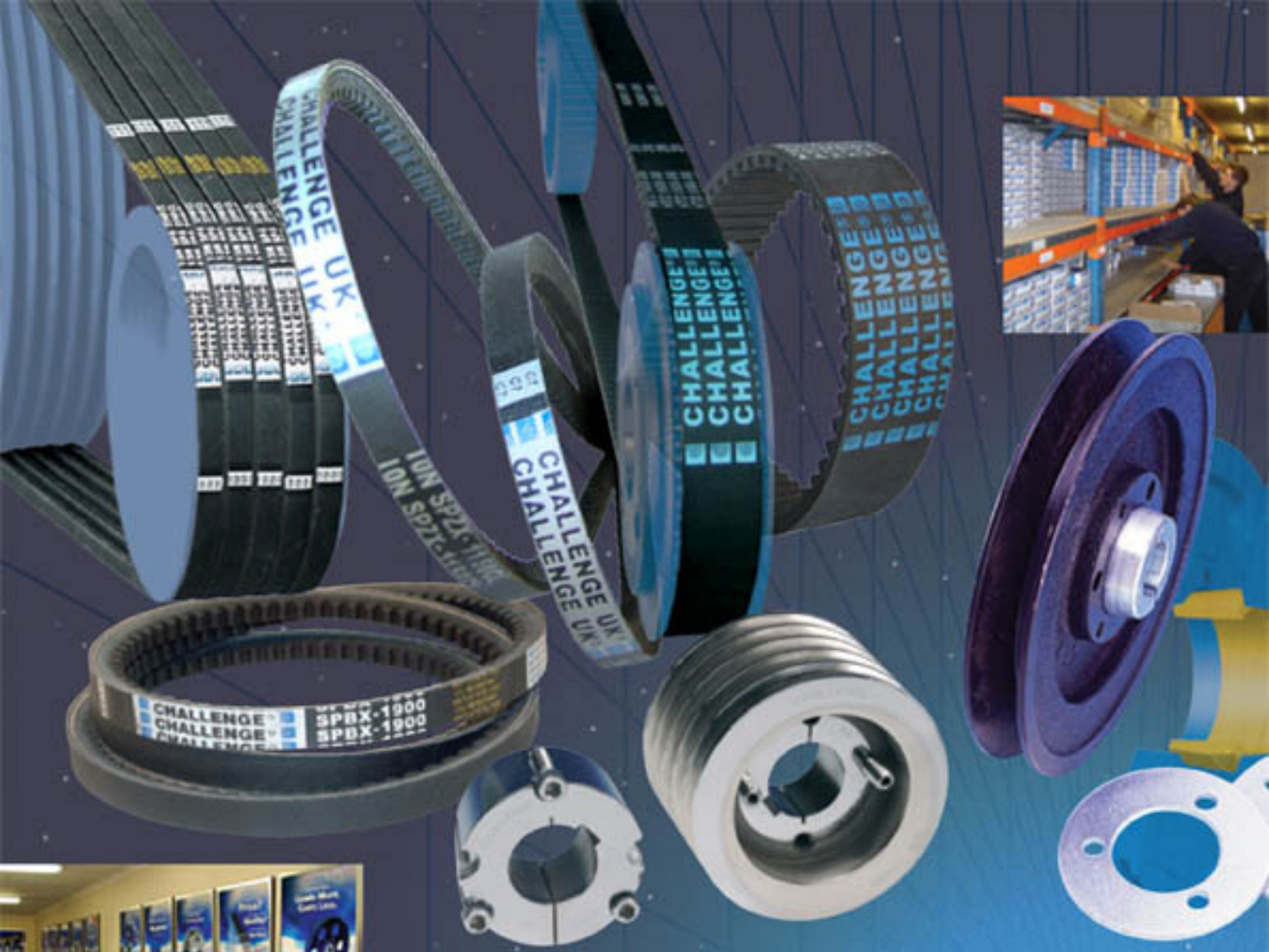

Never a problem, always a...

CHALLENGE®



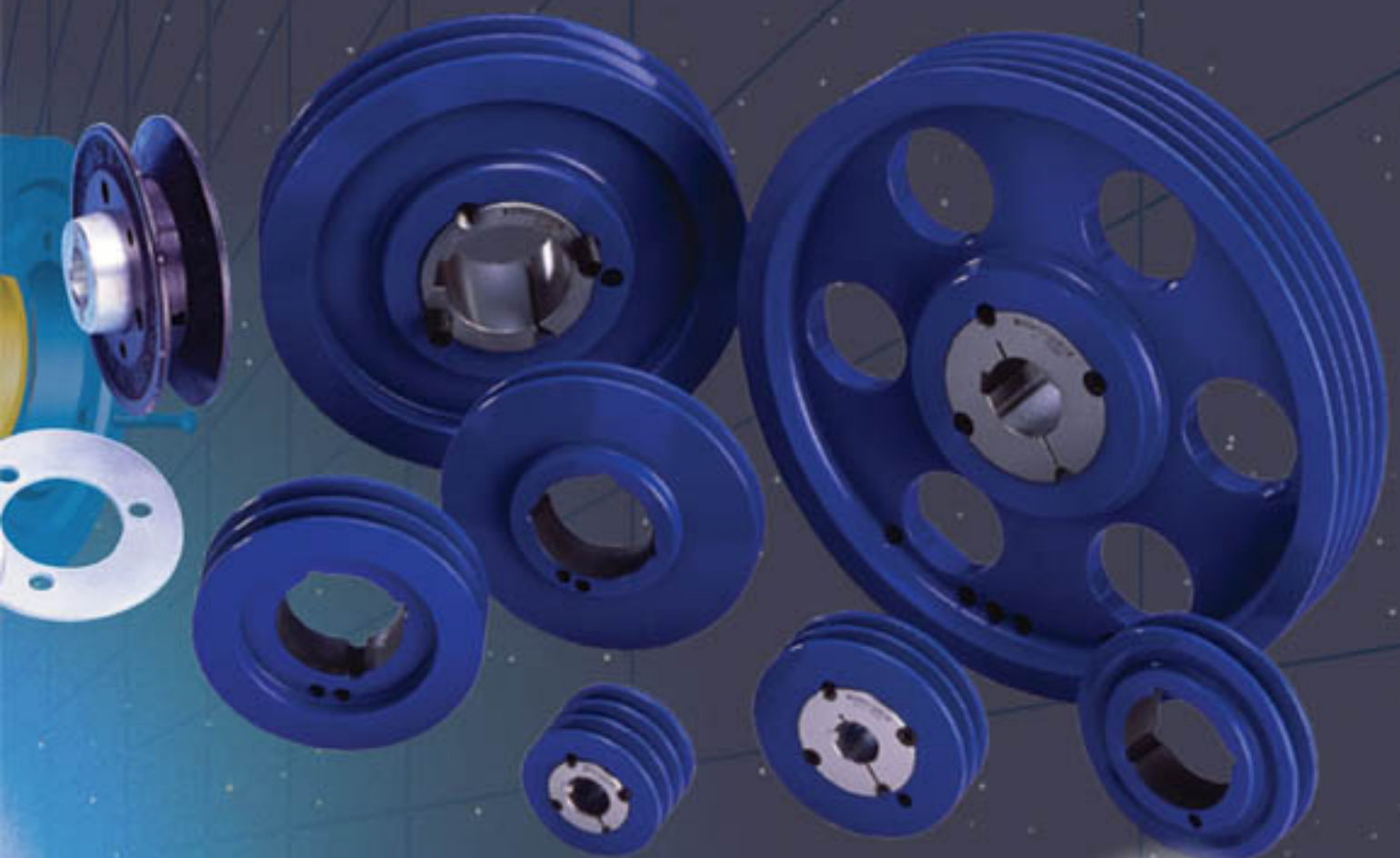

Challenge Group Companies



AUSTRALIA

Challenge Power Transmission (Aust) Pty Ltd
Tel: (03) 9763 6701 Fax: (03) 9764 0890
Email: aussales@challengept.com



CZECH REPUBLIC

Challenge PT (Czech) s.r.o
Tel: +420 573 334 106 Fax: +420 573 330 556
Email: czsales@challengept.com



GERMANY

Challenge Power Transmission GmbH
Tel: +49 2772 575860 Fax: +49 2772 5758620
Email: desales@challengept.com



IRELAND

Challenge Power Transmission (Ireland) Ltd
Tel: +353 1 4566311 Fax: +353 1 4566312
Email: ireland@challengept.com



CHINA

Challenge Power Transmission (Ningbo) Ltd
Tel: +86 574 8833 4378 Fax: +86 574 8833 4379
Email: ningbo.sales@challengeproduction.com



CHINA

Challenge Power Transmission (SHZ) Plc
Tel: +86 311 8538 5510 Fax: +86 311 8538 5590
Email: cnsales@challengept.com



SOUTH AFRICA

Challenge Power Transmission Africa (Pty) Ltd
Tel: +27 11 3975115 Fax: + 27 11 3978494
Email: sasales@challengept.com



UNITED KINGDOM

Challenge Power Transmission Ltd
Tel: +44 1902 866116 Fax: +44 1902 866117
Email: uk@challengept.com

Never a problem always a ...

CHALLENGE

